

# Large Size Electric Servo Drive Injection Molding Machine

# J-EL III SERIES

## Specifications

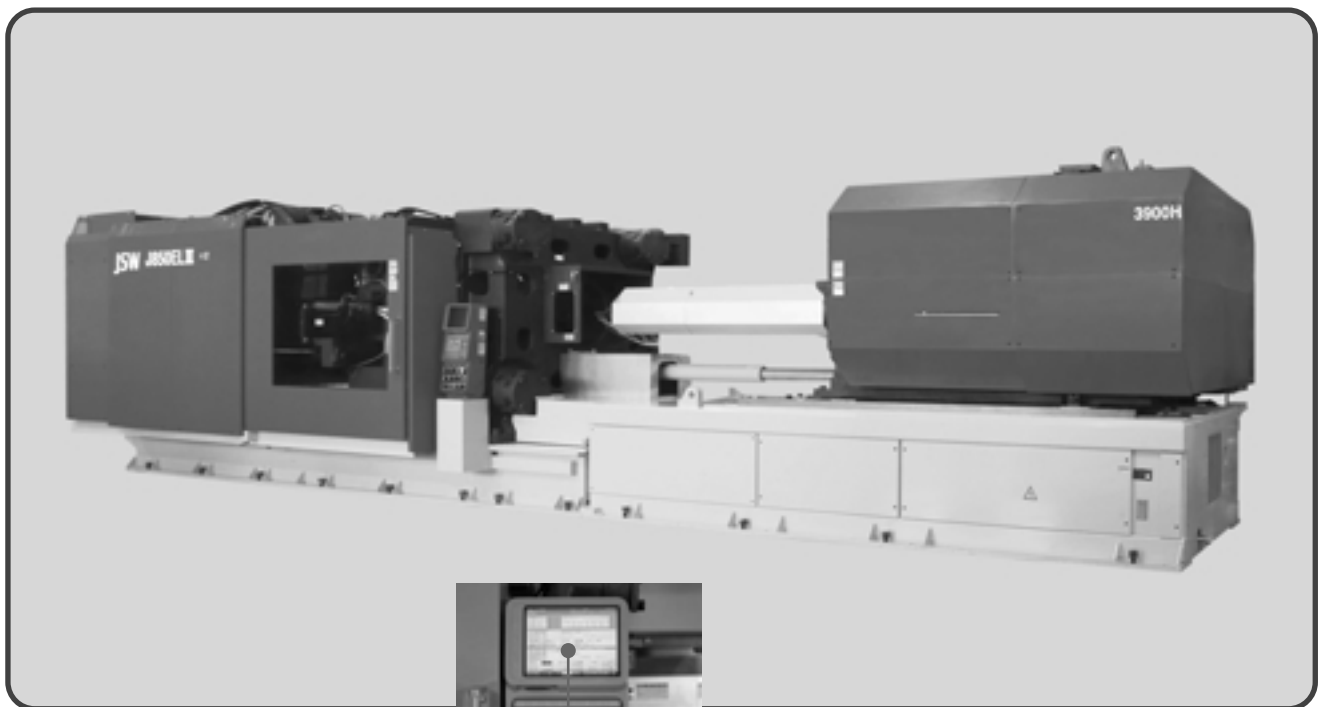

**SYSCOM2000 TFT Color LCD  
Controller with Touch Panel**



**Injection-Compression  
(Standard Spec.)**



**High Plasticizing Screw Cylinder**

Performance Table

Unit	Item	Model	J1000ELIII					
			3100H		3900H		5200H	
Injection Unit	Screw cylinder type		A	B	A	B	A	B
	Screw diameter	mm	92	100	100	110	110	120
	Screw stroke	mm	460		500		550	
	Theoretical injection capacity	cm <sup>3</sup>	3058	3613	3927	4752	5227	6220
	Injection capacity (GP-PS)	g	2783	3288	3574	4324	4757	5660
	Injection pressure (Max.)	MPa {kgf/cm <sup>2</sup> }	185 {1880}	156 {1590}	185 {1880}	153 {1560}	172 {1750}	144 {1460}
	Holding pressure (Max.)	MPa {kgf/cm <sup>2</sup> }	167 {1700}	140 {1420}	167 {1700}	138 {1400}	155 {1580}	130 {1320}
	Injection speed	mm/s	160		160		160	
	Injection rate	cm <sup>3</sup> /s	1064	1257	1257	1521	1521	1810
	Plasticizing rate (GP-PS)	kg/h	470	580	500	620	580	720
	Screw speed	min <sup>-1</sup>	165		140		130	
	Nozzle touch force	kN {tf}	59.0 {6.0}		59.0 {6.0}		59.0 {6.0}	
	Nozzle stroke from platen	mm	50					
	Type of nozzle		Open nozzle					
	Cylinder temperature control		Cylinder 4 / Nozzle 1					
Heater wattage	kW	45.2		47.0		55.0		
Clamping Unit	Mechanism		Double toggle					
	Clamping force	kN {tf}	9810 {1000}					
	Daylight opening (Max.)	mm	2500					
	Opening stroke (Max.)	mm	1300					
	Mold height	mm	500~1200					
	Distance between tie-bars (H×V)	mm	1320×1320					
	Platen size (H×V)	mm	1900×1900					
	Ejector type		29 points					
	Ejector force	kN {tf}	230 {23.5}					
	Ejector stroke	mm	200					
General	Machine weight	t	67		71		71	
	Machine dimensions (L×W×H)	m	11.70×2.97×2.92		12.20×2.97×2.92		12.34×2.97×2.92	

## Remarks:

1. Injection pressure of J-EL III series is different from that of JSW's hydraulic machines.
2. Maximum injection pressure and maximum holding pressure may be restricted due to molding condition.
3. The theoretical injection capacity is (cross sectional area of cylinder) × (stroke of screw).
4. The injection capacity is applicable for GP-PS and variable according to the grade of resin, molding conditions and mold.
5. The plasticizing rate is applicable for GP-PS.
6. PC (polycarbonate), HPVC, other engineering plastic, etc., low temperature setting and high speed molding may require a high torque depending on the grade or molding conditions. Please contact us if you plan.

## Note:

1. Due to continual improvements, specifications are subject to change without notice.
2. Actual figures of the specification will vary depending on final machine configuration. Please contact us if you require more specific data.
3. Performance specifications are based on theoretical data.
4. 1MPa=10.2 kgf/cm<sup>2</sup>, 1kN=0.102tf

Performance Table

Unit	Item	Model	J1300ELIII					
			3900H		5200H		7800H	
Injection Unit	Screw cylinder type		A	B	A	B	A	B
	Screw diameter	mm	100	110	110	120	110	120
	Screw stroke	mm	500		550		825	
	Theoretical injection capacity	cm <sup>3</sup>	3927	4752	5227	6220	7840	9331
	Injection capacity (GP-PS)	g	3574	4324	4757	5660	7135	8491
	Injection pressure (Max.)	MPa {kgf/cm <sup>2</sup> }	185 {1880}	153 {1560}	172 {1750}	144 {1460}	180 {1830}	151 {1530}
	Holding pressure (Max.)	MPa {kgf/cm <sup>2</sup> }	167 {1700}	138 {1400}	155 {1580}	130 {1320}	162 {1650}	136 {1380}
	Injection speed	mm/s	160		160		150	
	Injection rate	cm <sup>3</sup> /s	1257	1521	1521	1810	1425	1696
	Plasticizing rate (GP-PS)	kg/h	500	620	580	720	570	660
	Screw speed	min <sup>-1</sup>	140		130		150	140
	Nozzle touch force	kN {tf}	59.0 {6.0}		59.0 {6.0}		59.0 {6.0}	
	Nozzle stroke from platen	mm	50					
	Type of nozzle		Open nozzle					
	Cylinder temperature control		Cylinder 4 / Nozzle 1				Cylinder 6 / Nozzle 2	
Heater wattage	kW	47.0		55.0		59.0		
Clamping Unit	Mechanism		Double toggle					
	Clamping force	kN {tf}	12800 {1300}					
	Daylight opening (Max.)	mm	2800					
	Opening stroke (Max.)	mm	1500					
	Mold height	mm	650~1300					
	Distance between tie-bars (H×V)	mm	1400×1400					
	Platen size (H×V)	mm	2000×2000					
	Ejector type		29 points					
	Ejector force	kN {tf}	300 {30.5}					
	Ejector stroke	mm	250					
General	Machine weight	t	89		89		91	
	Machine dimensions (L×W×H)	m	13.02×3.07×3.08		13.22×3.07×3.08		14.17×3.07×3.08	

Remarks:

1. Injection pressure of J-EL III series is different from that of JSW's hydraulic machines.
2. Maximum injection pressure and maximum holding pressure may be restricted due to molding condition.
3. The theoretical injection capacity is (cross sectional area of cylinder) × (stroke of screw).
4. The injection capacity is applicable for GP-PS and variable according to the grade of resin, molding conditions and mold.
5. The plasticizing rate is applicable for GP-PS.
6. PC (polycarbonate), HPVC, other engineering plastic, etc., low temperature setting and high speed molding may require a high torque depending on the grade or molding conditions. Please contact us if you plan.

Note:

1. Due to continual improvements, specifications are subject to change without notice.
2. Actual figures of the specification will vary depending on final machine configuration. Please contact us if you require more specific data.
3. Performance specifications are based on theoretical data.
4. 1MPa=10.2 kgf/cm<sup>2</sup>, 1kN=0.102tf

Performance Table

Unit	Item	Model	J1300ELIIIW					
			3900H		5200H		7800H	
Injection Unit	Screw cylinder type		A	B	A	B	A	B
	Screw diameter	mm	100	110	110	120	110	120
	Screw stroke	mm	500		550		825	
	Theoretical injection capacity	cm <sup>3</sup>	3927	4752	5227	6220	7840	9331
	Injection capacity (GP-PS)	g	3574	4324	4757	5660	7135	8491
	Injection pressure (Max.)	MPa {kgf/cm <sup>2</sup> }	185 {1880}	153 {1560}	172 {1750}	144 {1460}	180 {1830}	151 {1530}
	Holding pressure (Max.)	MPa {kgf/cm <sup>2</sup> }	167 {1700}	138 {1400}	155 {1580}	130 {1320}	162 {1650}	136 {1380}
	Injection speed	mm/s	160		160		150	
	Injection rate	cm <sup>3</sup> /s	1257	1521	1521	1810	1425	1696
	Plasticizing rate (GP-PS)	kg/h	500	620	580	720	570	660
	Screw speed	min <sup>-1</sup>	140		130		150	140
	Nozzle touch force	kN {tf}	59.0 {6.0}		59.0 {6.0}		59.0 {6.0}	
	Nozzle stroke from platen	mm	50					
	Type of nozzle		Open nozzle					
	Cylinder temperature control		Cylinder 4 / Nozzle 1				Cylinder 6 / Nozzle 2	
Heater wattage	kW	47.0		55.0		59.0		
Clamping Unit	Mechanism		Double toggle					
	Clamping force	kN {tf}	12800 {1300}					
	Daylight opening (Max.)	mm	2800					
	Opening stroke (Max.)	mm	1500					
	Mold height	mm	650~1300					
	Distance between tie-bars (H×V)	mm	1700×1400					
	Platen size (H×V)	mm	2300×2000					
	Ejector type		29 points					
	Ejector force	kN {tf}	300 {30.5}					
	Ejector stroke	mm	250					
General	Machine weight	t	97		97		99	
	Machine dimensions (L×W×H)	m	13.02×3.37×3.08		13.22×3.37×3.08		14.17×3.37×3.08	

Remarks:

1. Injection pressure of J-EL III series is different from that of JSW's hydraulic machines.
2. Maximum injection pressure and maximum holding pressure may be restricted due to molding condition.
3. The theoretical injection capacity is (cross sectional area of cylinder) × (stroke of screw).
4. The injection capacity is applicable for GP-PS and variable according to the grade of resin, molding conditions and mold.
5. The plasticizing rate is applicable for GP-PS.
6. PC (polycarbonate), HPVC, other engineering plastic, etc., low temperature setting and high speed molding may require a high torque depending on the grade or molding conditions. Please contact us if you plan.

Note:

1. Due to continual improvements, specifications are subject to change without notice.
2. Actual figures of the specification will vary depending on final machine configuration. Please contact us if you require more specific data.
3. Performance specifications are based on theoretical data.
4. 1MPa=10.2 kgf/cm<sup>2</sup>, 1kN=0.102tf

Performance Table

Unit	Item	Model	J1800ELIII			
			5200H		7800H	
Injection Unit	Screw cylinder type		A	B	A	B
	Screw diameter	mm	110	120	110	120
	Screw stroke	mm	550		825	
	Theoretical injection capacity	cm <sup>3</sup>	5227	6220	7840	9331
	Injection capacity (GP-PS)	g	4757	5660	7135	8491
	Injection pressure (Max.)	MPa {kgf/cm <sup>2</sup> }	172 {1750}	144 {1460}	180 {1830}	151 {1530}
	Holding pressure (Max.)	MPa {kgf/cm <sup>2</sup> }	155 {1580}	130 {1320}	162 {1650}	136 {1380}
	Injection speed	mm/s	160		150	
	Injection rate	cm <sup>3</sup> /s	1521	1810	1425	1696
	Plasticizing rate (GP-PS)	kg/h	580	720	570	660
	Screw speed	min <sup>-1</sup>	130		150	140
	Nozzle touch force	kN {tf}	59.0 {6.0}			
	Nozzle stroke from platen	mm	50			
	Type of nozzle		Open nozzle			
	Cylinder temperature control		Cylinder 4 / Nozzle 2		Cylinder 6 / Nozzle 2	
Heater wattage	kW	55.0		59.0		
Clamping Unit	Mechanism		Double toggle			
	Clamping force	kN {tf}	17700 {1800}			
	Daylight opening (Max.)	mm	3200			
	Opening stroke (Max.)	mm	1700			
	Mold height	mm	800~1500			
	Distance between tie-bars (H×V)	mm	1850×1620			
	Platen size (H×V)	mm	2550×2320			
	Ejector type		37 points			
	Ejector force	kN {tf}	380 {38.7}			
	Ejector stroke	mm	300			
General	Machine weight	t	129		131	
	Machine dimensions (L×W×H)	m	14.08×3.72×3.51		14.94×3.72×3.51	

Remarks:

1. Injection pressure of J-EL III series is different from that of JSW's hydraulic machines.
2. Maximum injection pressure and maximum holding pressure may be restricted due to molding condition.
3. The theoretical injection capacity is (cross sectional area of cylinder) × (stroke of screw).
4. The injection capacity is applicable for GP-PS and variable according to the grade of resin, molding conditions and mold.
5. The plasticizing rate is applicable for GP-PS.
6. PC (polycarbonate), HPVC, other engineering plastic, etc., low temperature setting and high speed molding may require a high torque depending on the grade or molding conditions. Please contact us if you plan.

Note:

1. Due to continual improvements, specifications are subject to change without notice.
2. Actual figures of the specification will vary depending on final machine configuration. Please contact us if you require more specific data.
3. Performance specifications are based on theoretical data.
4. 1MPa=10.2 kgf/cm<sup>2</sup>, 1kN=0.102tf

Equipment Dimensions and Mold Related Dimensions

J1000EL III

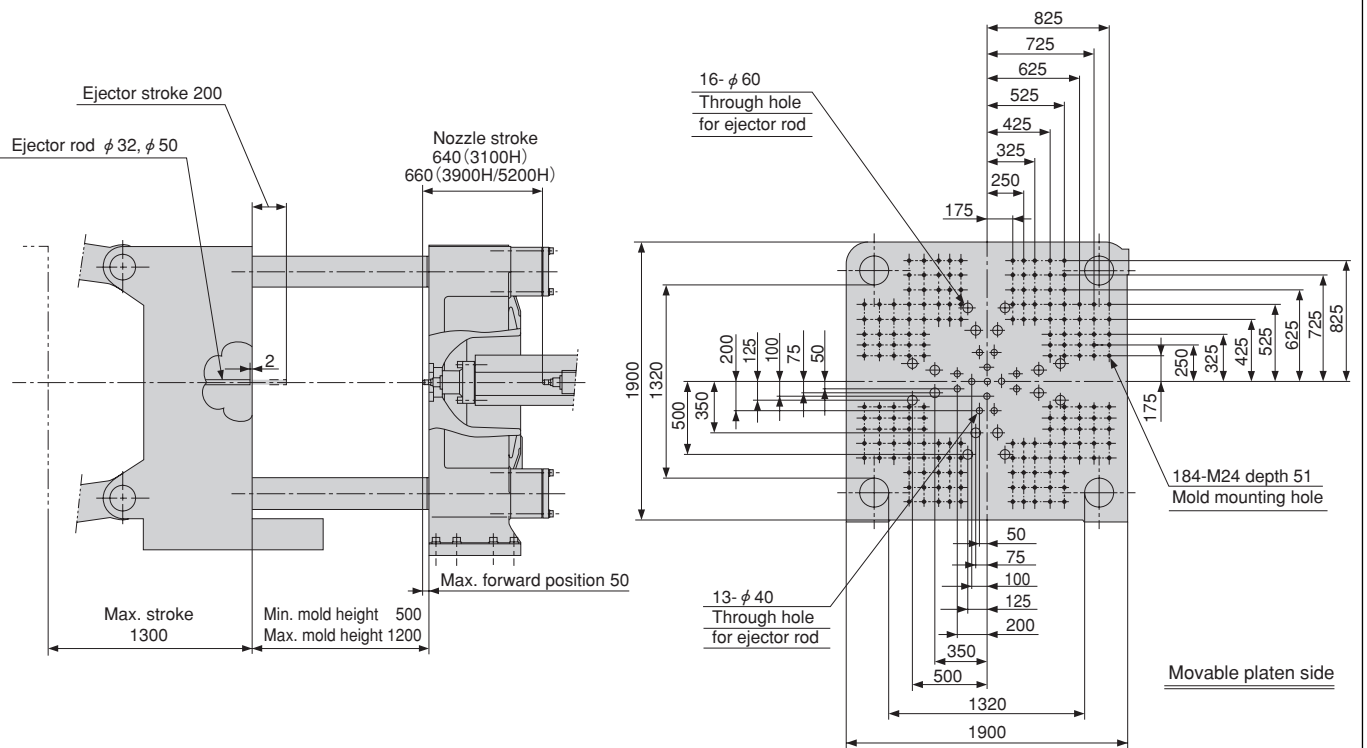
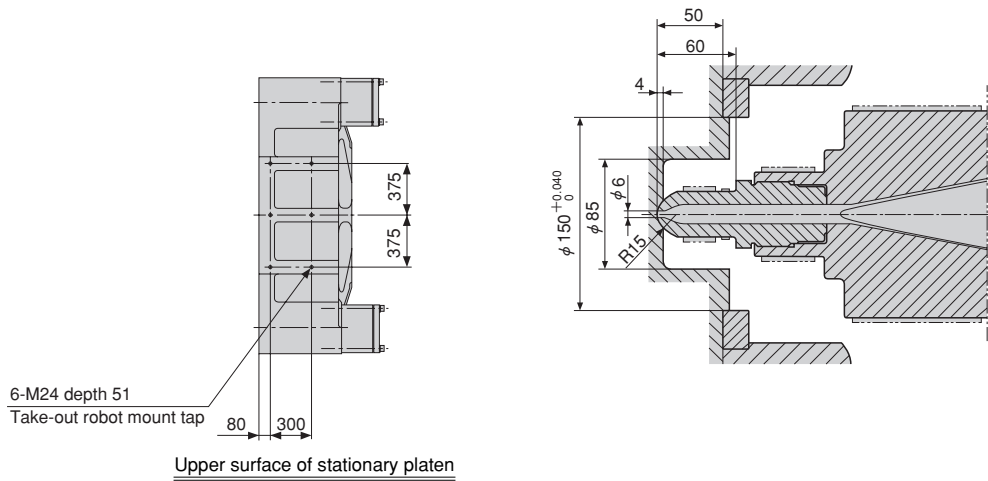
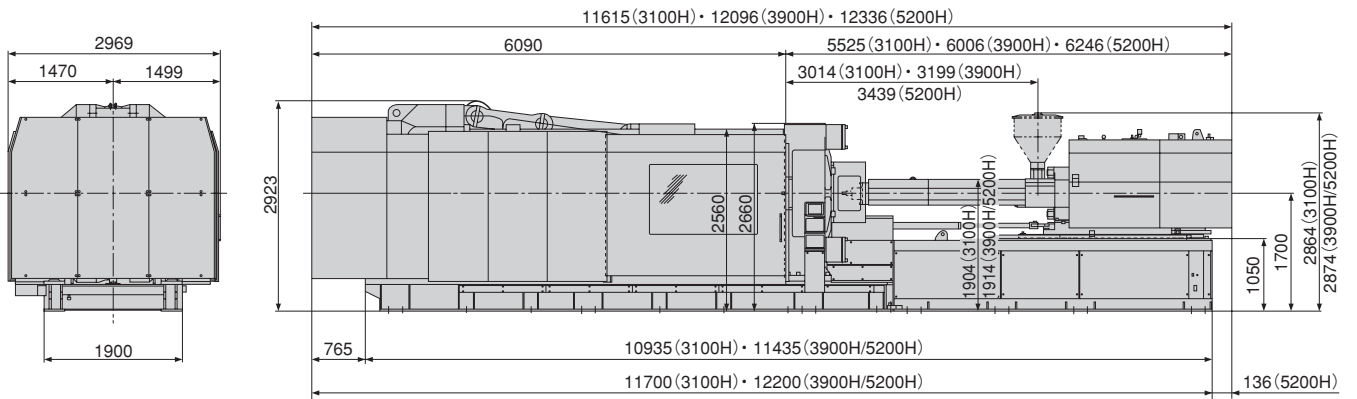

Equipment Dimensions and Mold Related Dimensions

J1300EL III

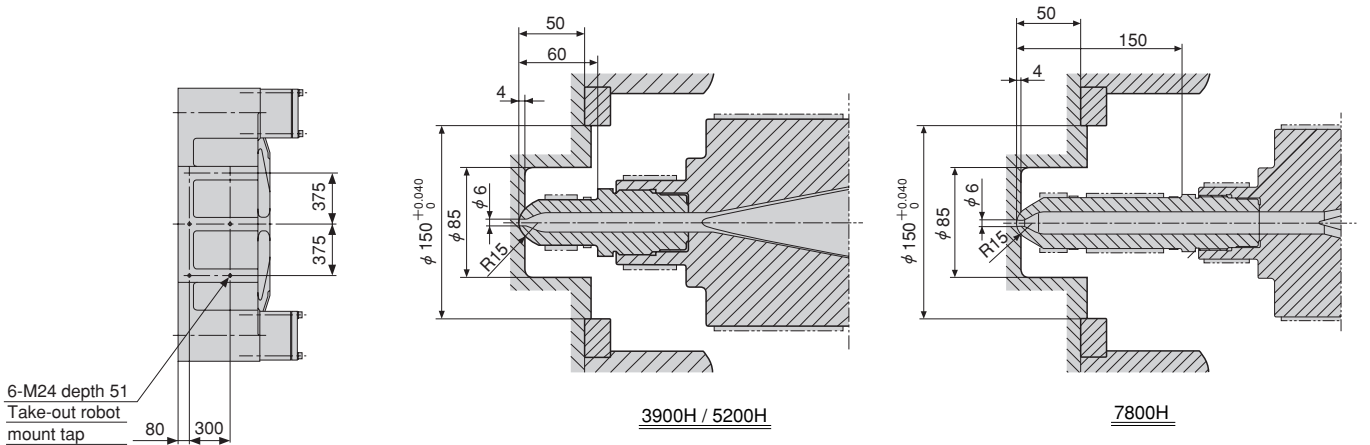
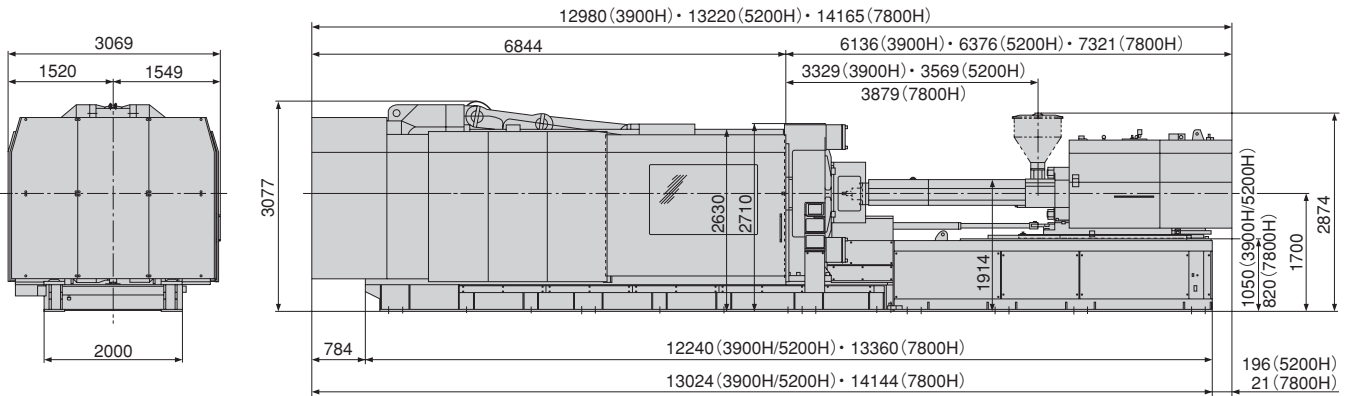

Upper surface of stationary platen

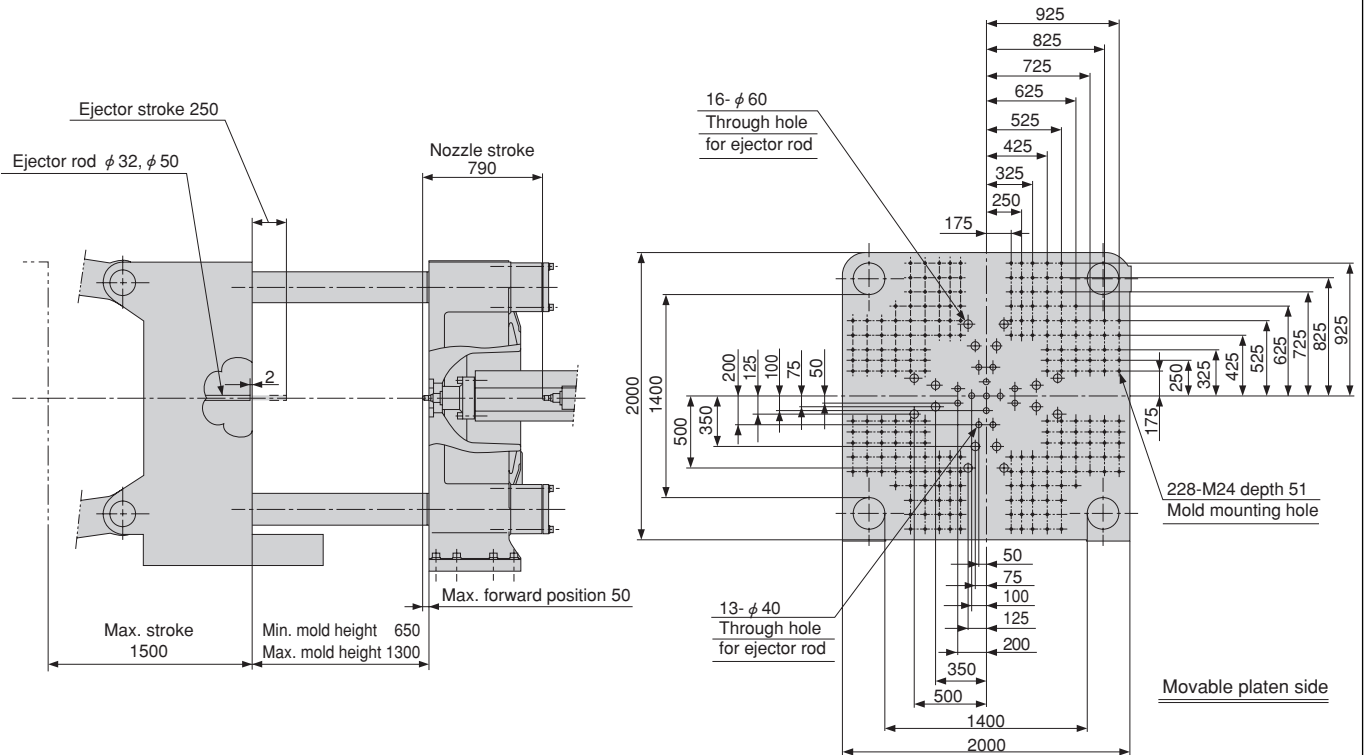

# Equipment Dimensions and Mold Related Dimensions

## J1300EL III W

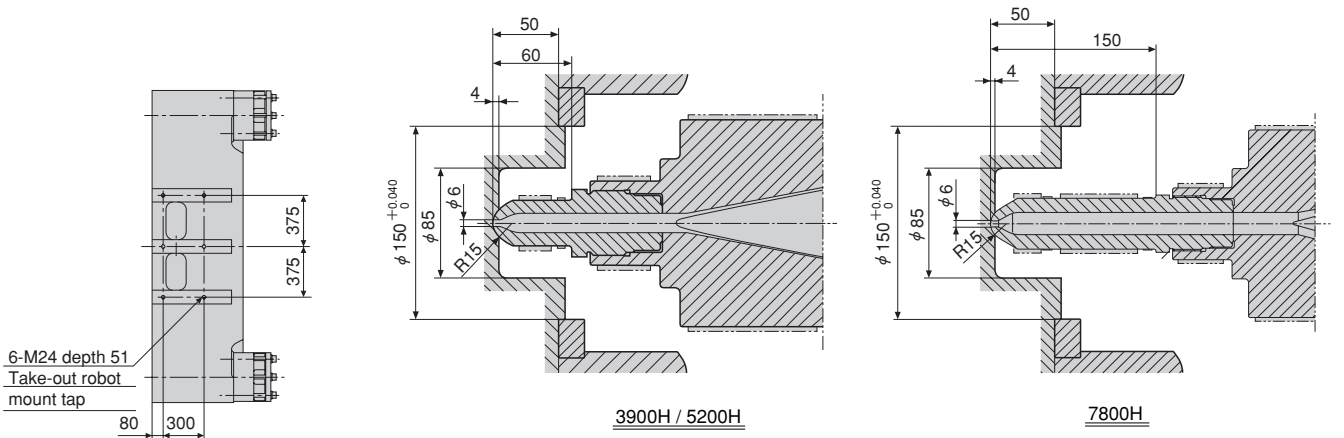
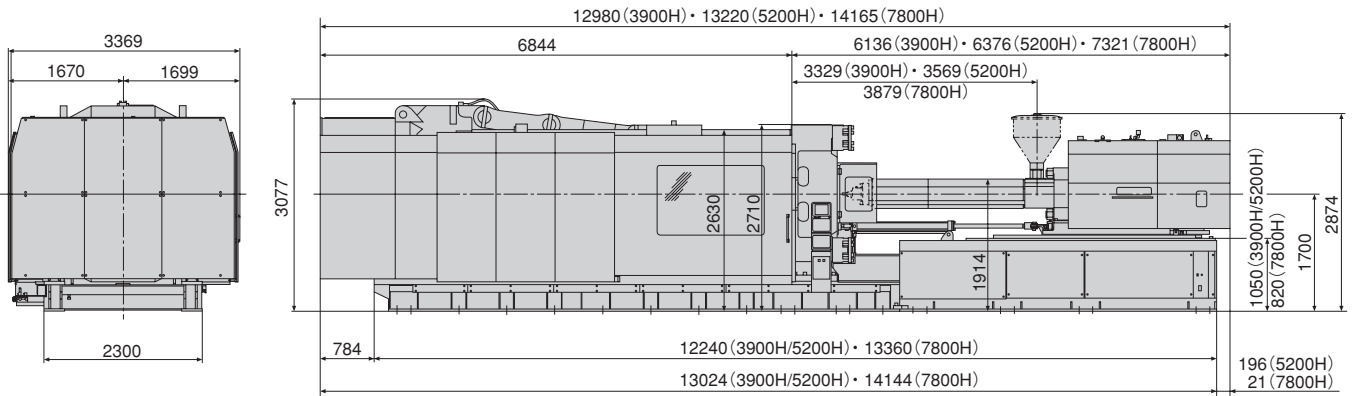

Upper surface of stationary platen

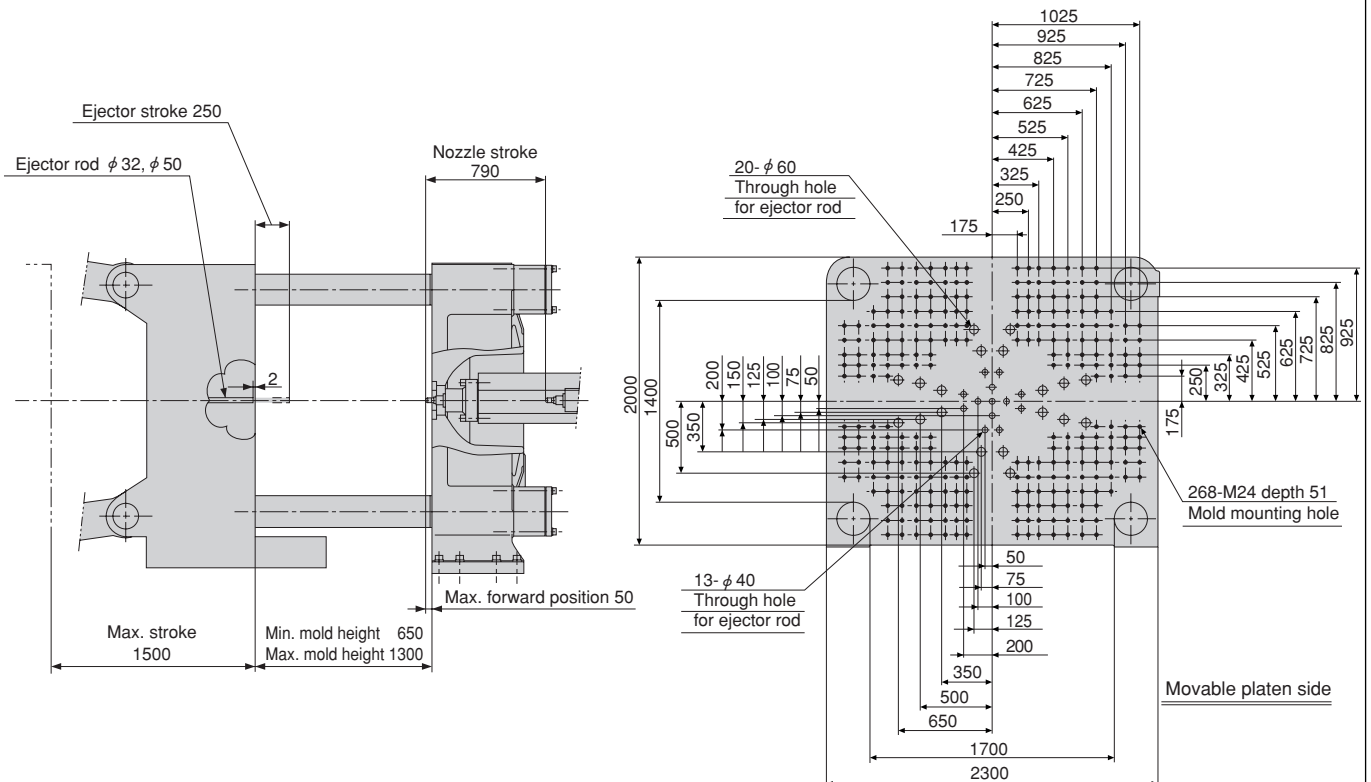

Equipment Dimensions and Mold Related Dimensions

J1800EL III

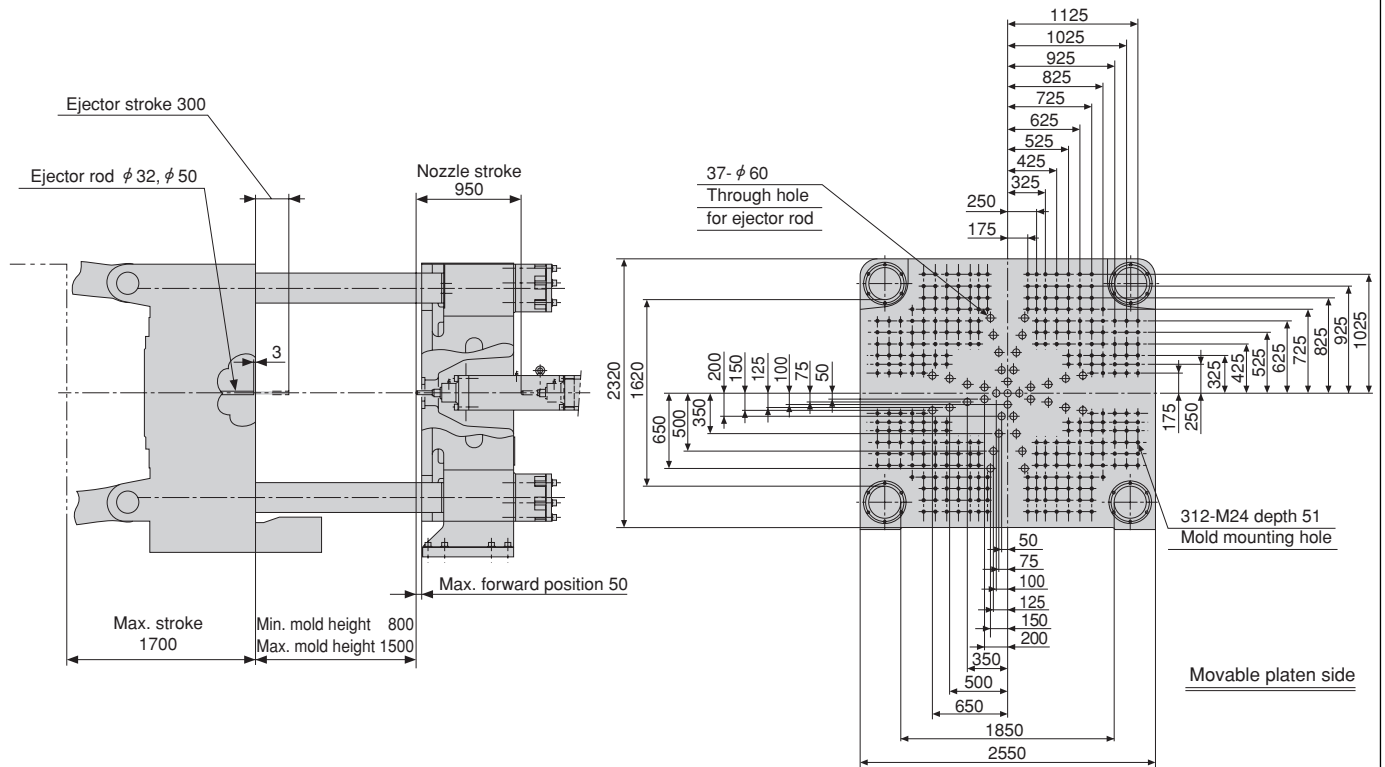
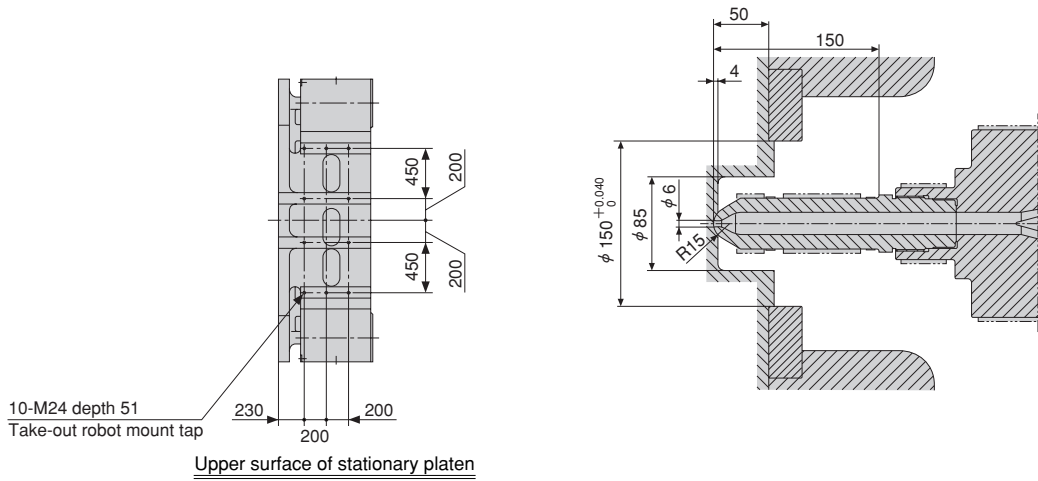
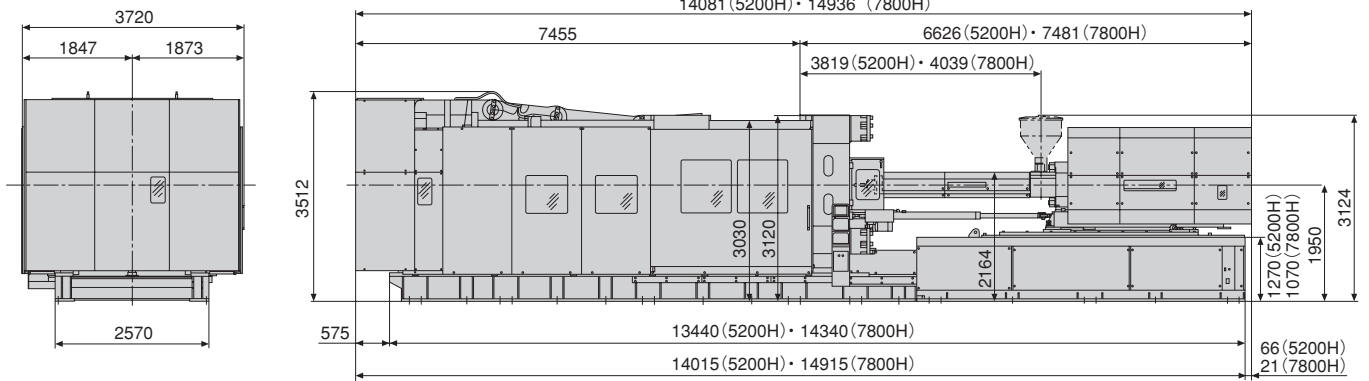

## Standard Equipment

Unit item		
Injection and Plasticizing		
Standard open nozzle		
Screw cylinder	1)	
High-melter MIII screw	2)	
Screw suck back		
Purge cover (with LS)		
Swivel injection unit	3)	
Cold screw start-up prevention		
Molding/Pause temperature changeover function		
Automatic purging circuit		
Sprue break timing selection		
Suck back timing selection		
Injection and rotation program control (Closed-loop control)	Injection speed	1~6 steps
	Injection pressure	steps
	Holding pressure	
	Screw speed	1~3 steps
	Screw back pressure	steps
Transfer to holding pressure by sensing Injection speed (IVS)		
Automatic greasing		
Cylinder temperature control	4)	
Nozzle temperature control (SSR)		
Cylinder temperature remote setting		
Soft pack servo control		
Mold Clamping Unit		
Self-lubricating toggle bushings		
Automatic greasing		
High performance moving platen support		
Remote setting of mold open/close speed		
Remote setting of moving platen position		
Remote setting of ejector speed		
Remote setting of ejector position		
Automatic mold height adjustment		
Remote setting of mold height		
Automatic mold clamping force setting		
Compression molding (1~6 steps)		
Mold protection device		
Safety devices (electrical and mechanical)		
Take-out robot mounting holes		

Notes:

- 1) N2000F cylinder for 1400H injection unit, and nitride cylinder for 2300H and up.
- 2) GP2 screw for 1400H injection unit.
- 3) Manual operation type for 1400H injection unit.
- 4) Solid state control (SSR) for 1400H injection unit and magnetic contactor control (MC) for 2300H and up.
- 5) The printer, printer cable and receptacle are optional.
- 6) The Japanese/English switching function is standard equipment.
- 7) Sensor and cable are not included.

## Optional Equipment

Unit item	
Controller	
TFT color LCD controller with SYSCOM touch panel	
Storage of molding conditions	
Data card	
Soft touch start-up function	
Printer output terminal	5)
Self-diagnostic function	
Overall set screen	
Emergency stop button switch	
Safety key	
Dual function	
Time clock	
Unmanned operation switch	
Robot interface	
Japanese/English switching function	6)
Monitor	
Cylinder temperature monitoring function	
Heater circuit break	
Injection pressure monitor (IPM)	
Injection wave form monitor	
Injection wave form storage	
Statistical graph display	
Table display	
Display of mold temperature	7)
Lubrication failure alarm	
Abnormal alarm buzzer	
Production monitoring	8)
Operating time display	
Cycle monitor	
Molding condition upper/lower limit	9)
Maintenance	10)
Alarm history	
Set value history	
Servo alarm	
General	
Mold cooling water closed circuit (with flow indicator)	
Accessories (Maintenance tools and ejector rods)	

Unit item	
Injection	
Long nozzle	
SVN shut-off nozzle (spring type)	
Wear and corrosion-resistant cylinder	
Wear and corrosion-resistant screw	
Wide selection of screws	
Cylinder heat insulating cover	
Cylinder cooling unit (with blower)	
Shut-off nozzle (hydraulic or pneumatic)	
Hopper	
Hopper stage	
Mold Clamping unit	
Daylight extension	
T-grooved mold platen	
Spacer plate	
Air jet	
Core puller circuit (hydraulic or pneumatic)	
Unscrewing motor control circuit	
Gate-cut circuit	
Automatic opening safety door	
Automatic opening and closing safety door	
Special locating ring	
Safety mat switch	
Cooling water closed circuit (stationary platen type)	
Ejector plate return confirmation circuit	
Mold mounting preparation unit	
Controller and Others	
Abnormal mold temperature warning	
Hot runner control circuit	
Language switching function	11)
Alarm light	
Communication function with host computer	
Printer (with printer cable)	
Printer cable (IBM compatible)	
Data card (40 sets mold/card)	
Calendar timer	
Plug socket for auxiliary equipment	
Levelling pads	

- 8) Setting of production quantity and advance notice are possible and completion time is displayed.
- 9) Monitoring functions of the following particulars are equipped as standard. (Cycle time, Injection time, Rotation time, Mold opening-closing time. Cushion, Injection start position, Changeover position to holding pressure, Injection pressure, Changeover pressure to holding, Screw back pressure)
- 10) Maintenance service time and areas are displayed.
- 11) One more language can be added, in addition to Japanese and English.

## Utilities

### Total Power Capacity

Machine Model	Total Power Capacity (kVA)	
J550EL III	1400H	51
	2300H	56
	3100H	66
J650EL III	2300H	57
	3100H	68
	3900H	82
J850EL III J850EL IIIW	3100H	68
	3900H	83
	5200H	86
J1000EL III	3100H	69
	3900H	84
	5200H	87
J1300EL III J1300EL IIIW	3900H	84
	5200H	88
	7800H	93
J1800EL III	5200H	89
	7800H	93

Notes: Total power capacity does not include external outlets.

### Required Water Quantity for Cylinder Hopper

Machine Model	Required Water Quantity for Cylinder Hopper (m <sup>3</sup> /h)
1400H	0.6
2300H	1.2
3100H	
3900H	
5200H	1.6
7800H	

Notes: The above figures do not include the required quantity of water for the mold temperature controller.