

# **JT** **AD** **SERIES**

All Electric Servo Drive Vertical Type Injection Molding Machine

**JSW**

# High Quality Compact Design.

JSW has produced a super-advanced all-electric vertical type injection molding machine - it is faster, more precise, and more compact.

The JT-AD series machines have been evolving to match the needs of today and beyond: They display high productivity on in-line assembly.

Using the advanced technologies that have been fostered for many years and are unique to JSW, we have achieved high-precision injection molding.

**Compact body**  
Low table height and smaller foot print.

**Facilities Performance**

**Productivity**  
Faster table rotation and mold open/close.

**Faster Cycles**

**Molding quality**  
62 micro second high-speed servo control circuit that is among the fastest in the industry.

**Algorithm Technology**

**Operability and visibility**  
Large 15-inch LCD color display.

**Innovative & Friendly Operation**

**Handling a variety of products**  
Wide selection range of injection modules and injection capability, with flexible control.

**Wide Range of Injection Units Performance**



JT40RAD



JT40AD

# JT AD SERIES

All Electric Servo Drive Vertical Type Injection Molding Machine



## Low-Profile and Compact Design

This compact machine is easy to operate and suitable for in-line configuration.

### Space saving

The machine width and installation space have been greatly reduced, to make possible inclusion of the machine on the assembly line. JT40RAD has reduced machine width by 150 mm and installation space by 18%, when compared with conventional models. (comparison between our JT-EL III & AD Series machines)

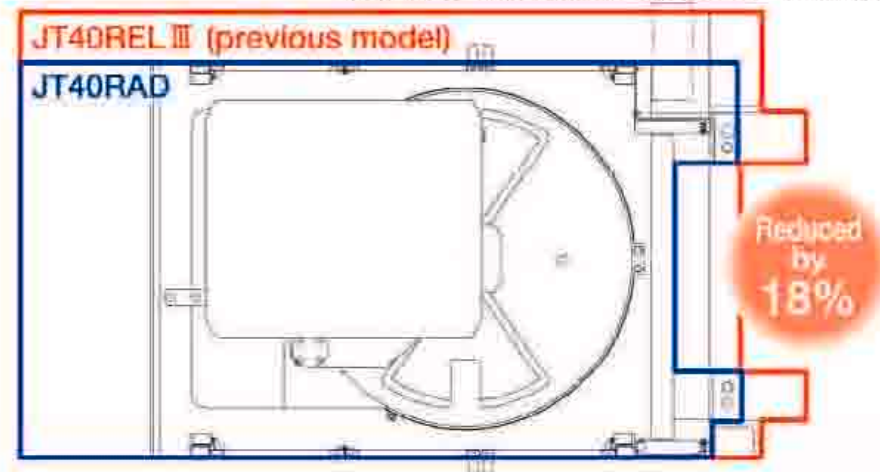

### Larger molds

Although the machine width is more compact, the outer diameter of the table is the same as that of conventional models: Optimizing the nozzle position makes it possible to mount larger molds, and the machine can also handle larger, more complex dies, such as sliding cores. (comparison between our JT-EL III & AD Series machines)

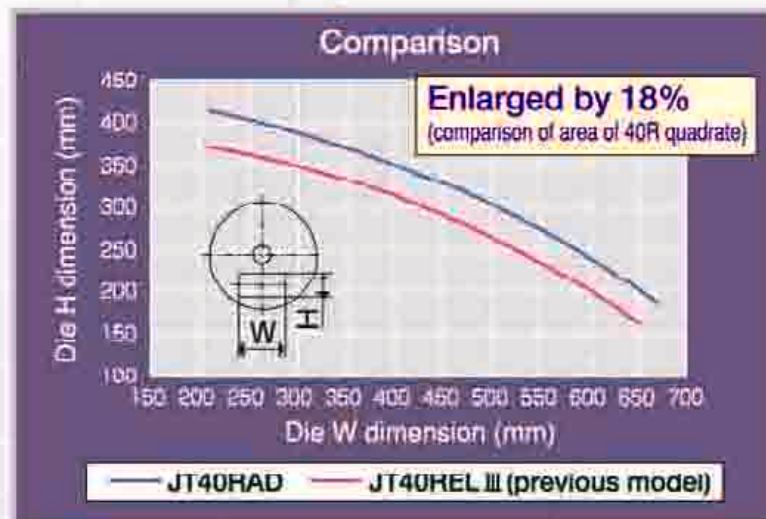

- Using new clamp design exclusively for the vertical machine has resulted in both table and overall height reduction.
- The use of dual control panel has reduced the machine width and footprint.
- Approaching a mold in 3+1 directions is standard, and the use of three-piece safety door improves operability and facilitates access to maintenance.

### Compact table

The mold securing height has been reduced to allow the assembly line to be lowered, making it easier for the operator. With a JT40RAD-55V, the table height is 894 mm (35.2 inch), 146 mm (5.75 inch) lower than on conventional machines; the machine height of 2850 mm (112.2 inch) is the most compact in the industry (including mounting pads). (comparison between our JT-EL III & AD Series machines)

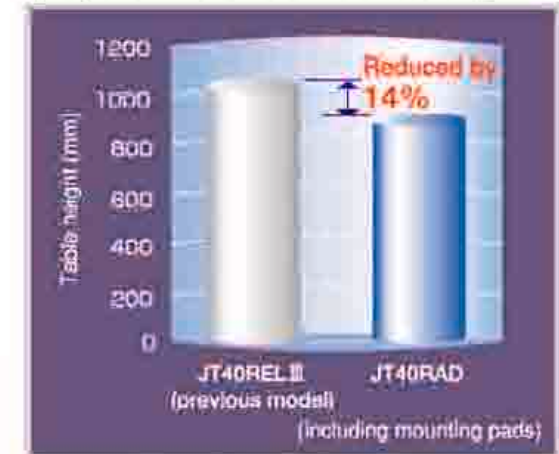
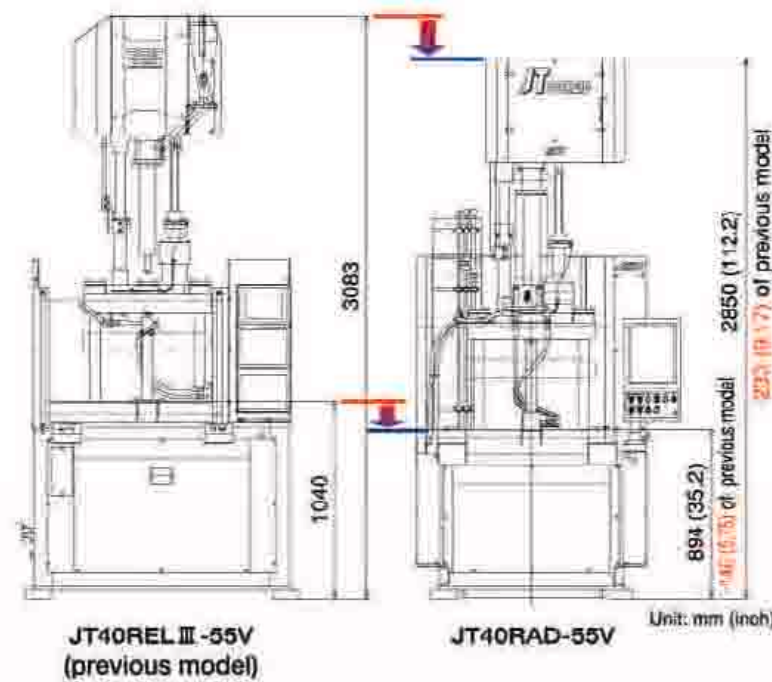

### Mold accessible in three directions

A three-piece safety door is used: The door open/close area is smaller. This improves operability and ease of machine installation. A mold can be accessed from three directions - both sides of the machine and the operation side - and an open space is left on the opposite side from operation, so that a runner can be easily removed.



# Faster Cycles

## High-speed mold open/close and fast table rotation, improve productivity.

Faster cycles for mold open/close and rotary table rotation have been achieved.

High-speed clamp and smooth mold opening/closing are achieved by using a clamping mechanism exclusively for the vertical machine: This was designed to optimize the toggle link and reduce the weight of moving the clamp assembly. The table rotation control has been improved to achieve high-speed table rotation, thereby reducing lost time, and increasing productivity.

### Fast, smooth mold open/close operation is ensured

A clamping mechanism exclusively for vertical machine with high-capacitance servo motor shortens the mold open/close dry cycle by 21% (JT40RAD). This redesign results in high-speed, smooth mold open/close operation and facilitates high-cycle molding.

(comparison between our JT-ELIII & AD Series machines)

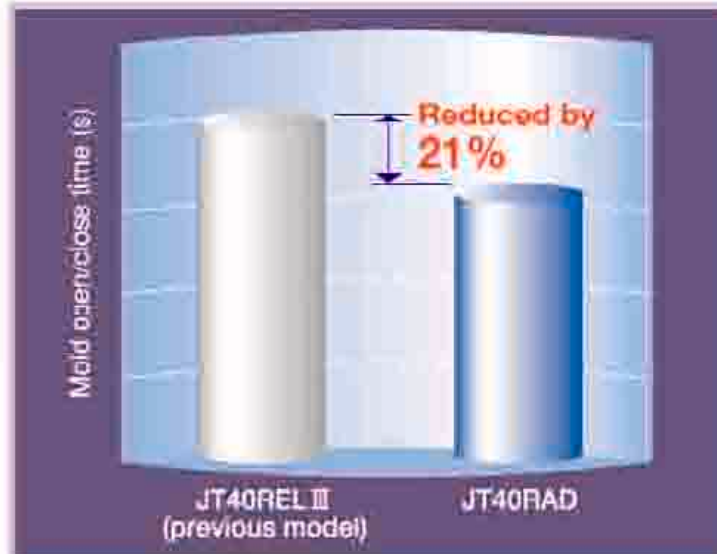

### High-performance servo motor & timing belt

Silent, high-speed table rotation - the best in the industry - has been achieved by using a high-performance servo motor and timing belt. A mechanical stopper is provided at the rotation stop end to improve the stop accuracy during repetitive operation: This enables stable molding without any displacement of the inserted product. (The table rotates 180 deg. for reciprocated turning.)

(comparison between our JT-EL III & AD Series machines)

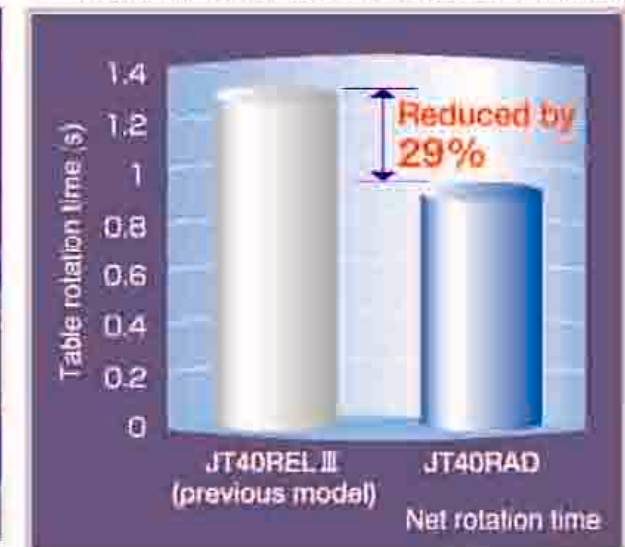
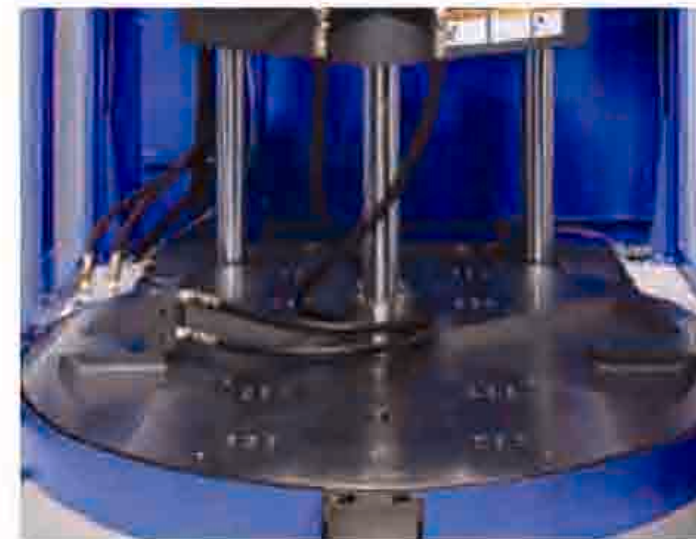

### Injection compression makes a wide variety of molding possible.

The injection compression molding function, unique to JSW, is equipped as standard: The injection compression controls the position of mold with accuracy more than 10 times that of direct-pressure molding machines, making possible a wide variety of molding (PAT. 1744469).

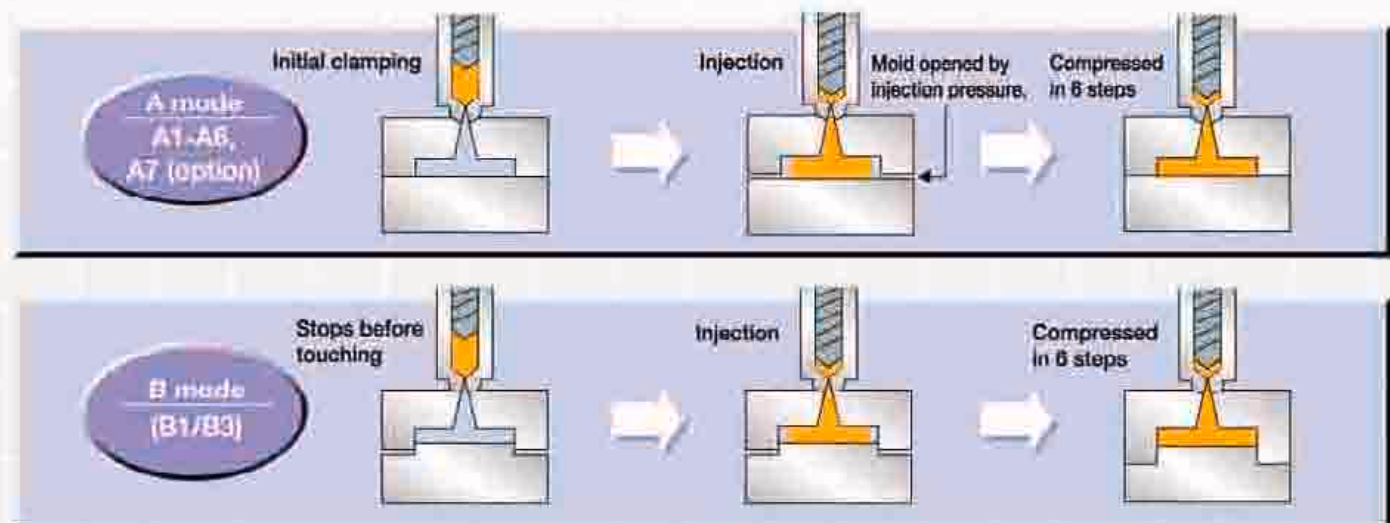
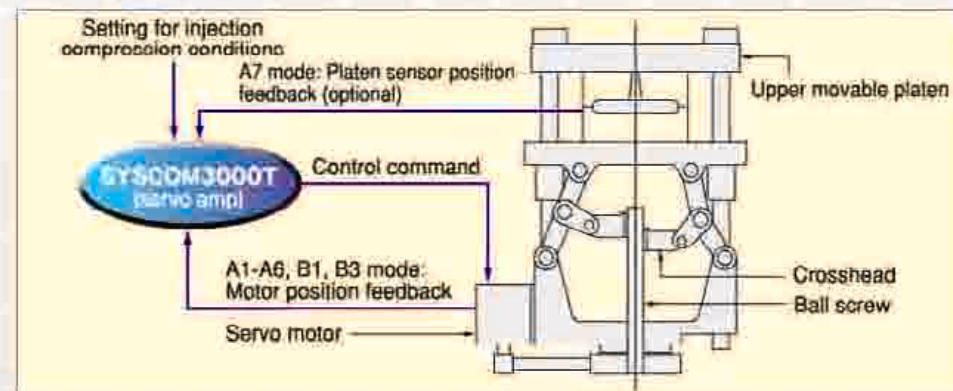



62 micro second high-speed servo control circuit, the fastest in the industry, improves the product quality.

Large 15 inch LCD color monitor  
Remarkably improved operability and visibility



The marvelous 62 micro second high-speed servo control circuit results in both high precision and stable quality.

Upgraded SYSCOM3000T.



Use of 62 micro second high-speed servo control circuit in the "JT-AD Series" reduces scanning time to 1/16<sup>th</sup> of conventional controls. It promotes product quality through a reduction in performance variation, such as holding transfer pressures.



JSW original high-speed servo control board

Variation in the holding transfer pressure (comparison between our JT-EL III & AD Series machines)

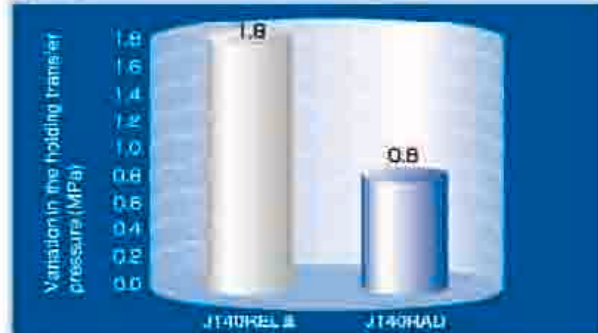

Variation in cushion (comparison between our JT-EL III & AD Series machines)



Variation in product weight (comparison between our JT-EL III & AD Series machines)

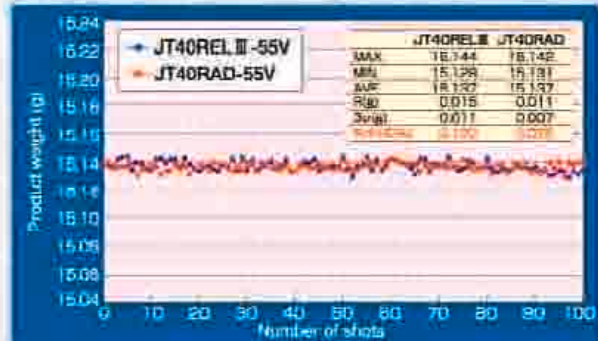

Molding machines: JT40REL III (conventional machine) vs JT40RAD-55V  
Molded Product: Electronic parts  
Resin: PA 6



The resolution of injection pressure detector has been greatly improved.

The resolution of the load cell amplifier for the injection pressure has been intensified five times for more accurate injection, holding and back pressure control which helps insure stabilized precision molding.

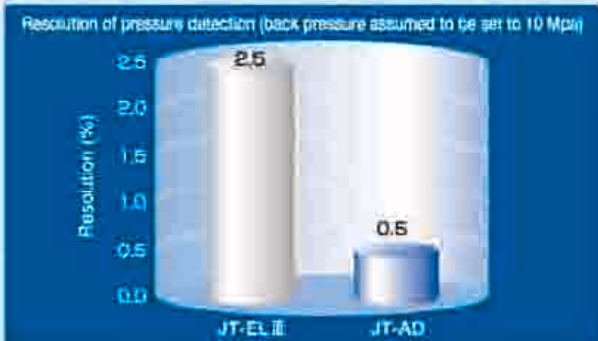

- A vertically arranged large 15 inch TFT color LCD screen. The controller rotates to provide the operator with a clear view of molding parameters.
- An illustration of the machine and a touch screen insures easy operation.
- The independent injection conditions can be set to conform the delicate difference between two lower molds. (Rotary type specification)
- Languages are selectable from English, Chinese and Japanese even during running. Other languages (Korean and Spanish) are optional.
- Up to 120 molding conditions can be stored in internal memory; up to 1,000 conditions can be stored in external memory (USB memory).



### SYSCOM3000T screens

A controller consists of the condition setting screen, mode keys screen and operation switches.

Condition setting screen

Touch panel screen

Selector switches

Condition setting screens



Cycle monitor screen

Item	Unit	Value	Unit	Value
Cycle	1.000	0.000	0.000	0.000
PLU Time	0.000	0.000	0.000	0.000
PLU Time	0.000	0.000	0.000	0.000
PLU Time	0.000	0.000	0.000	0.000
PLU Time	0.000	0.000	0.000	0.000
PLU Time	0.000	0.000	0.000	0.000
PLU Time	0.000	0.000	0.000	0.000
PLU Time	0.000	0.000	0.000	0.000
PLU Time	0.000	0.000	0.000	0.000
PLU Time	0.000	0.000	0.000	0.000

Convenient monitoring screens



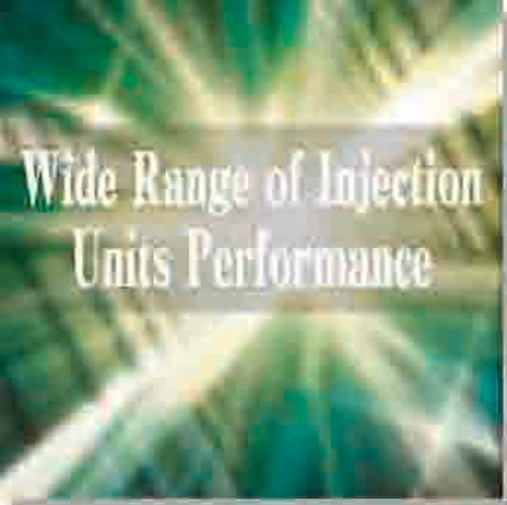

# A wide selection of injection units with versatile control modes promotes the product quality.

## Module system

The low inertial injection (HR) specifications (\*optional) and high-speed, high response injection (HS) specifications (\*optional) have been added on the module system that is highly accepted in the industry. The module system enables selection of opportune injection unit and covers diversified products including micro and thin-walled molding.

**Module system**

Single acting type	M40	M70	M100	Clamping module
20V	○			
55V	○	○	○	
110V		○	○	
220V			○	
Injection module				

The single acting type is under preparation.

Rotary type	M20R	M40R	M70R	M100R	M150R	Clamping module
20V	○	○				
55V	○	○	○	○	○	
110V		○	○	○	○	
220V			○	○	○	
Injection module						

Models marked \* are under preparation.

Note: High-speed, high-response injection (HS) specification applies to the injection unit marked ○.

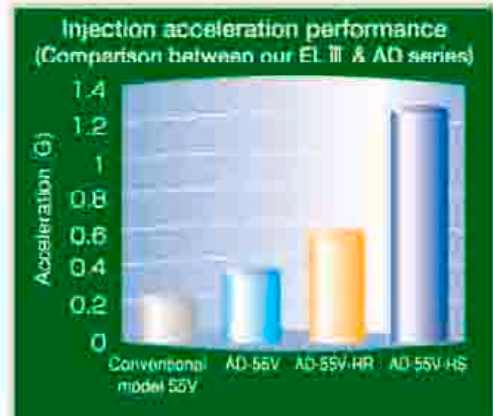

## JSW's unique injection control

### ■ IWCS (Injection Weight and Cushion Stability) control

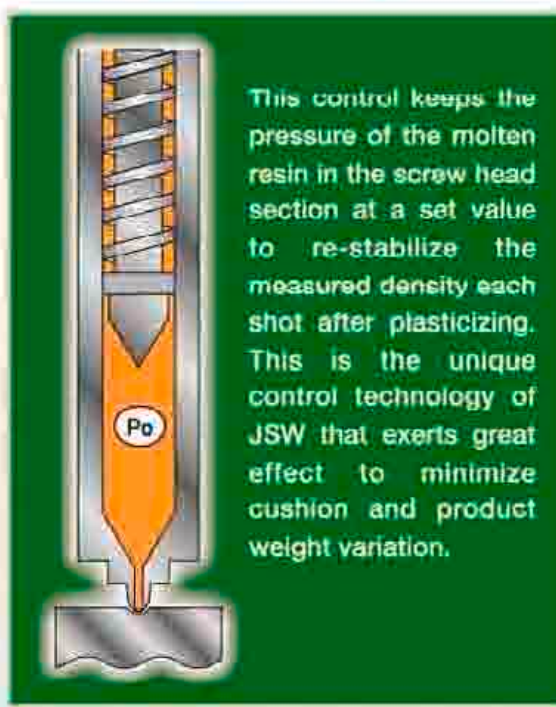

This JSW's unique function effectively stabilizes cushion and product weight fluctuation. (PAT. # 3529771)

### ■ Effect of reduced cushion variation

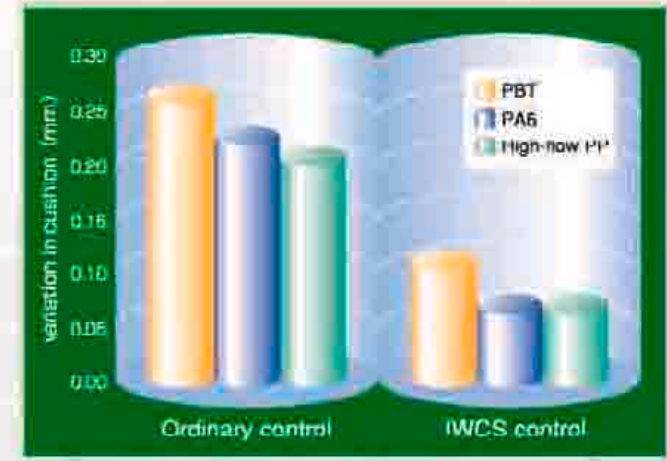

### ■ Electric-driven soft-pack servo control

This JSW unique control technology suppresses peak pressure immediately before switching the holding pressure in the injection process, keeping the machine pack at optimum pressure. It results in over-pack prevention in thin-wall molding. (PAT. # 1755568)

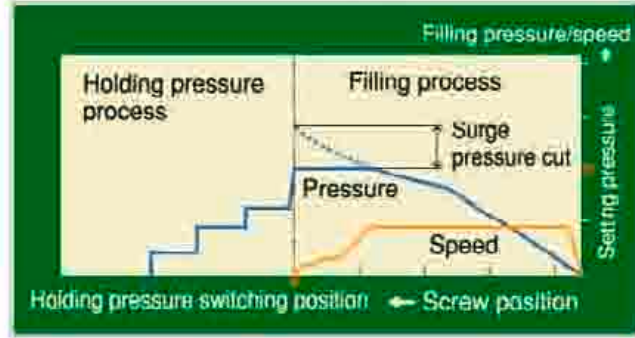

### Effects of soft-pack servo

- Molding distortion reduced
- Burrs cleared
- Dispersion in weight of molded products reduced
- Clamping force reduced (low-pressure molding)
- Mold-friendly

### ■ APC (Advanced Pressure Control)

This JSW unique control technology suppresses overshoots or undershoots of resin pressure during the filling/holding pressure process, a dramatic upgrade of the tracking and responsibility for setting pressure. (PAT. # 3168289)

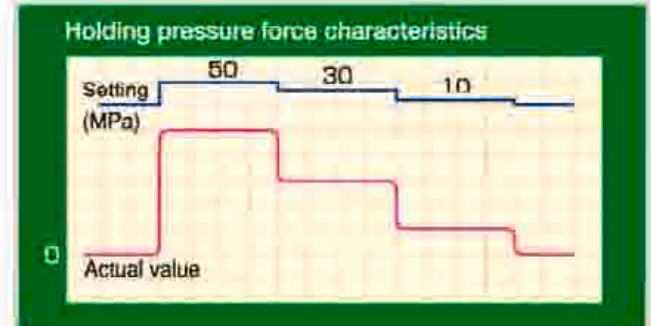
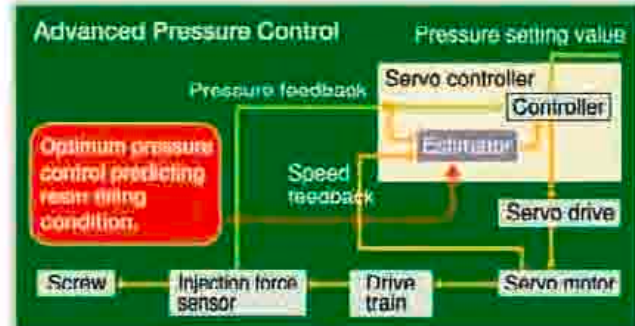

### ■ Predicted control of metering

To ensure smooth stops with optimum screw rotation and back pressure load at the screw rotation completion position, estimate control is located in the front of the screw rotation completion position. The screw rotation number can be reduced to the optimum without any loss in time, and back pressure can be decreased.

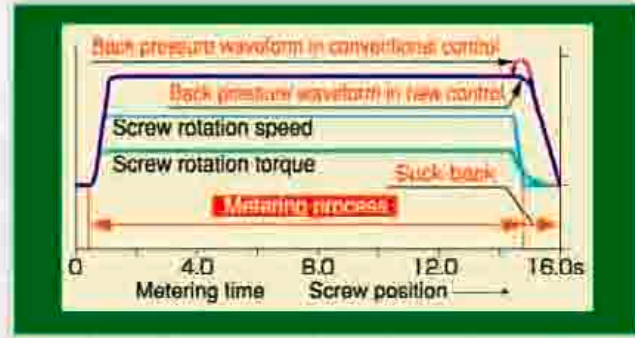

### ■ Before-holding pressure deceleration control

This control uses the estimate control to reduce the speed to the optimum holding pressure speed, from its position before the holding pressure transfer position. This decreases the inertia that is peculiar to electric injection molding machines and improves stability in holding pressure transfer pressure, which is essential for precision molding.

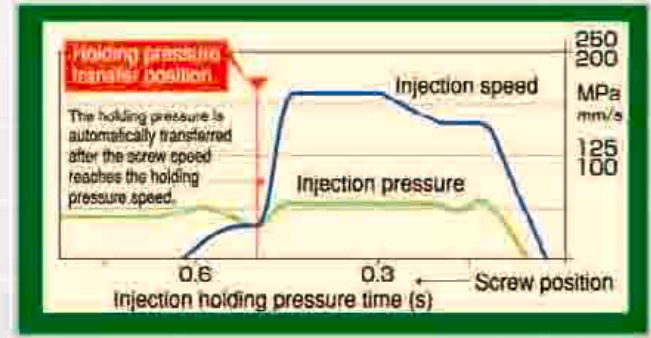

# Energy Saving

This efficient energy saving performance greatly reduces power consumption.



Advanced centralized monitoring system and remote management system.

# Remote Management

- Power consumption is 1/3 to 1/4 that of a hydraulic machine.
- Cooling water amount is less than 1/5 that of a hydraulic machine.

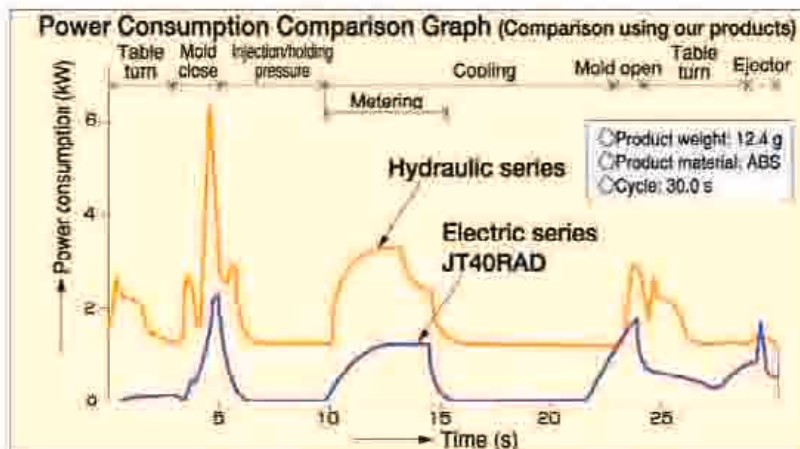

Power consumption	Electric series JT40RAD	Hydraulic series
kWh	0.58	2.16

Note: Power consumption by cylinder heater is not included.

Power consumption is reduced by 1/3 to 1/4, when compared with hydraulic machines.

## NET100 system and LINK10 system

This system performs both quality control and production control of injection molding machines. When the system is connected to the factory LAN, it will be possible to communicate data with the injection molding machines connected to network. Depending on the number of machines connectable to network, the NET100 system can control up to 100 machines, and the LINK10 system can control up to 10 machines. \* Optional

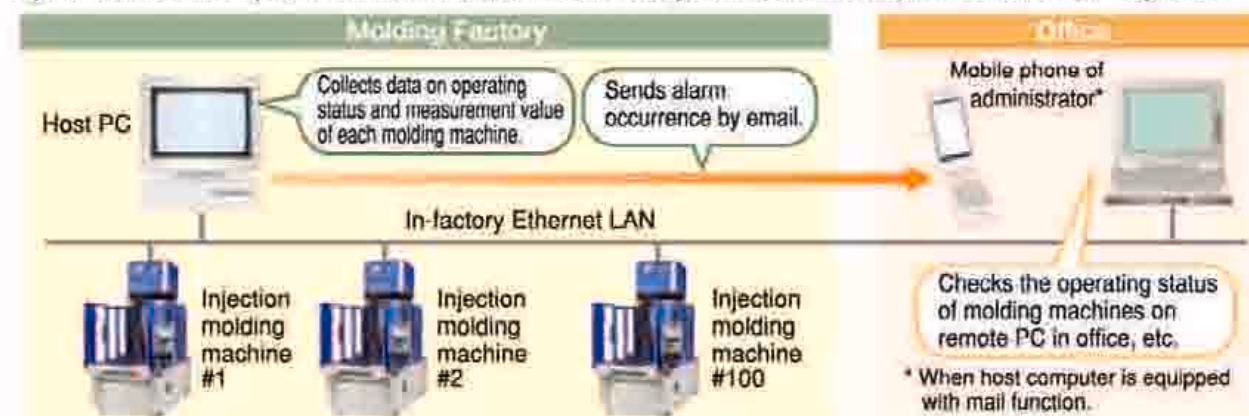

## Remote management system

Connecting the NET100 system or LINK10 system to the Internet will allow operator to monitor the molding status, display the controller screens and change settings from anywhere in the world. This will greatly increase the efficiency of molding work. \* Optional

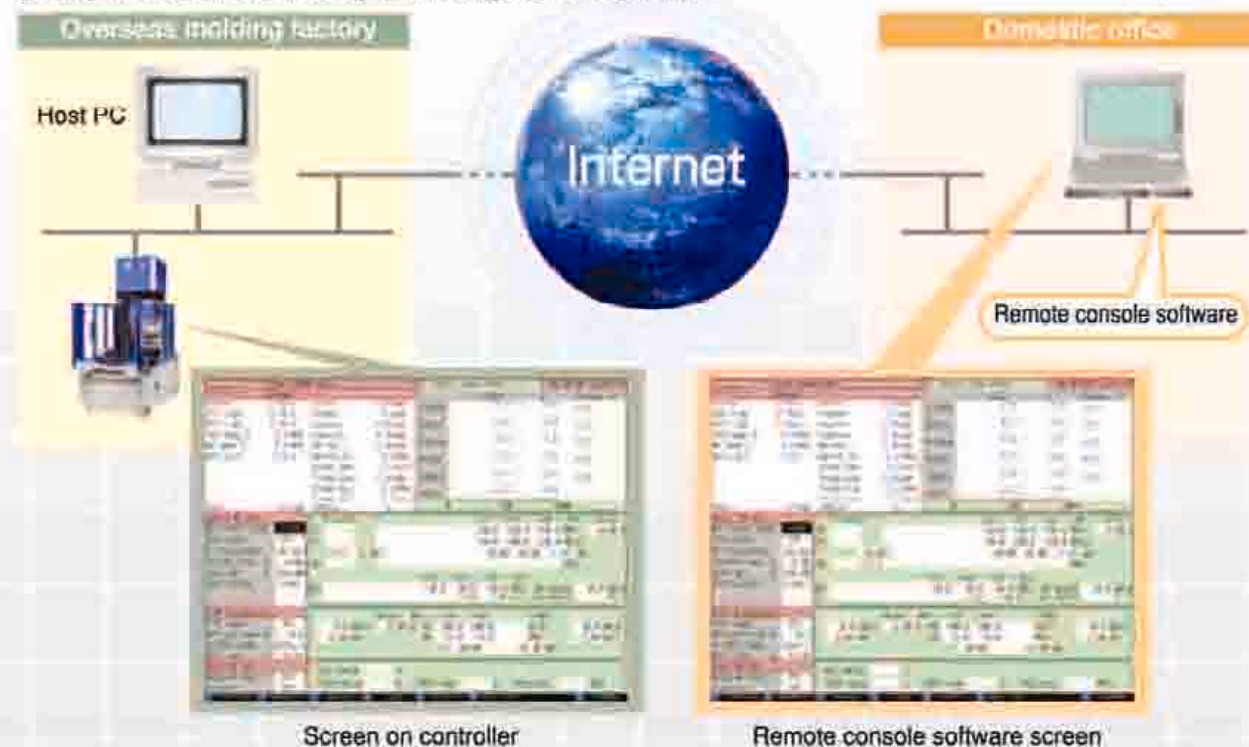

# Easy Maintenance

## Promotion of maintainability.

### ● Polycarbonate safety door

A large polycarbonate (steel is also available) safety door that allows operator to clearly view the inside of platen is used. The status of both mold and molded product is easily visible, to facilitate maintenance.



### ● Air pressure inspection window

The window allows operator to easily check the supply status of factory air that is necessary for the safety device of the machine.



### ● Automatic lubricating device

This automatically lubricates the injection and clamping devices to prevent any problem due to inadequate lubrication.



### ● Highly endurable ball screw

Using a ball screw that maintains high accuracy improves endurance.





# Maintaining the standard of high quality and reliable production

## List of standard accessories

Item		
Injection/plasticizing	KC nozzle (tip type)	
	N2000F barrel (corrosion/abrasion resistance type) Note 1	
	LSP-2 screw (abrasion resistance type) Note 1	
	HT screw head	
	Screw suck-back	
	Screw and barrel attachment/detachment device	
	Screw cold start prevention	
	Molding/Pause temperature select	
	Automatic purging circuit	
	Nozzle touch force remote setting	
	Nozzle retract select	
	Suck-back select	
	Automatic greasing	
	Injection/Metering programmed control	Injection/holding pressure: 1 to 6 steps (variable) Metering/back pressure: 1 to 3 steps (variable)
	Holding pressure transfer by speed detection (IVS control)	
Clamping	Barrel temperature remote setting	
	Barrel temperature control (SSR)	
	Soft pack servo control	
	Hopper flange temperature control	
	IWCS control	
	Reverse seal control	
	Holding pressure control select	
	Synchronous temperature rise control	
	Grease free toggle bushing	
	Automatic greasing	
	Mold open/close and ejection programmed control	Mold open/close: 4 steps (fixed) Ejection: 1 to 3 steps (variable)
	Electric-driven mold thickness adjusting device	
	Mold thickness remote setting	
	Auto clamping force setting	
	Toggle type injection compression function	A-mode B-mode Compression: 1 to 6 steps (variable)
Mold protection function		
Photoelectric safety device (rotary type only)		
Table speed remote setting (rotary type only)		
Clamping safety device (electric/mechanical type) Note 2		
Robot mounting holes		

Note 1: One set of K or A size screws is equipped in standard. B size is optional.  
Note 2: Photoelectric type is used for operation side of rotary type.  
Note 3: The external memory can store up to 1000 mold conditions. Prepare commercial USB data storage media.  
Note 4: Printer and printer cable are optional.

Item		
Controller	Touch-panel TFT color LCD controller	
	Molding condition storage (internal memory: 120 molds) Note 3	
	Lower two-die molding condition auto switching (rotary type only)	
	USB printer port Note 4	
	Self-diagnosis function	
	Overall setting screen	
	Help function	
	Pre-heat timer	
	Compound action	
	Clock	
	Attended/unattended operation select	
	Multi-language select (English/Chinese/Japanese)	
	Monitor	Barrel temperature monitor
		Heater system fault
		Injection pressure monitor (IPM)
Injection/metering waveform monitor		
Injection/metering waveform storage		
Oscilloscope waveform monitor		
Injection pressure overshoot alarm		
Statistical graph		
Measurement value display		
Mold temperature display Note 5		
Grease lubrication fault alarm		
Fault alarm buzzer		
Production monitor		
Cumulative operating hour display		
Cycle monitor		
Molding condition upper/lower limit monitor Note 6		
Inspection and maintenance Note 7		
Others	Alarm history	
	Set value history	
	Servo fault alarm	
Cooling water closed circuit		
	Accessories (maintenance tools, ejector rods)	

Note 5: Thermal sensor and electric wiring are not included.  
Note 6: A maximum of 8 items and alarms can be selected out of the following monitor items:  
① Cycle time ② Injection time ③ Metering time  
④ Cushion position ⑤ Holding pressure end position  
⑥ Injection pressure ⑦ Holding pressure transfer pressure  
⑧ Screw back pressure ⑨ Metering end position  
⑩ Injection start position ⑪ Holding pressure transfer position  
⑫ Mold open time ⑬ Mold close time ⑭ Metering torque  
⑮ Holding pressure transfer speed ⑯ Mold inner pressure (option)  
Note 7: Indicates inspection time and items.



## List of optional accessories

Item	
Injection	Long nozzle
	Shut-off nozzle (pneumatic type)
	Hi-Melta MII screw Note 1
	Ultra corrosion/abrasion resistance screw barrel Note 2
	B size screw barrel
	Hopper throat abrasion resistance sleeve
	Barrel insulation cover
	Hopper
	Hopper attachment tube
	Ceramic screw head
	PCD screw head
	Module 1 rank down sized barrel
	Residual resin alarm
	Low inertial injection (HR)
	High-speed/high-response injection (HS)
Vent-type injection device Note 3	
Clamping	Daylight extension
	Thermal insulation plate for platens Note 4
	Air jet
	Core pull circuit (pneumatic type, hydraulic type) Note 5
	Unscrewing motor circuit
	Die clamper
	Upper die ejector (hydraulic type) Note 5
	Ejector 3-point ejection (rotary type only)
	Ejector stroke extension (rotary machine only)
	Mold temperature control piping (for high temperature, rotary type only)
	Mold setup device (inside platen, outside platen) Note 6
	Mold one direction access (270 deg. rotation, rotary type only)
	Mold clamper

Note 1: Applied for screw diameters of 35 mm or more.  
Note 2: Consult us individually for specifications.  
Note 3: Screw diameters of 25 mm or more are compatible.  
Note 4: If an insulation board is equipped, note that both the nozzle stroke and the range of mold thickness used will be changed.  
Note 5: Pump unit is separately required for the hydraulic type.  
Note 6: When inside platen access device is equipped, the ejector stroke extension (option) is required.  
Note 7: Consult us separately for languages other than the above. English and Chinese are provided standard.  
Note 8: LINK10 has measurement value data collection, molding condition management and remote console functions.  
Note 9: The NET100 has quality control and production control functions in addition to the functions of LINK10.  
Note 10: For export specifications, separate meetings may be necessary depending on the destination.  
Note 11: Designated colors, referring to color samples or Munsell codes.

Item		
Electric installation/control	Other language select (Korean/Spanish) Note 7	
	Simple centralized monitoring system LINK10 Note 8	
	Centralized management system NET100 Note 9	
	Heater disconnection alarm	
	Mold temperature display (with mold temperature upper/lower limit alarm)	
	Mold temperature control device (heater type)	
	Printer (with printer cable)	
	Robot interface	
	Others	Cooling water flow indicator
		Cooling water failure warning
Leveling pads for installation		
Rotary warning light		
Export specifications Note 10		
Designated color Note 11		

### Examples of attaching optional devices



● External appearance and specifications of this machine are subject to change without notice to make improvements.  
● Unauthorized reprint from this catalog is prohibited.  
● Photos shown in this catalog include those of optional devices.

# **JSW THE JAPAN STEEL WORKS, LTD.**

URL <http://www.jsw.co.jp/>

Division Gate City Ohsaki-West Tower, 11-1, Osaki 1-chome, Shinagawa-ku,  
Head Quarter: Tokyo 141-0032, Japan  
Phone: +81-3-5745-2051 Fax: +81-3-5745-2053~54  
URL [http://www.jsw.co.jp/inj\\_f/inj\\_index.htm](http://www.jsw.co.jp/inj_f/inj_index.htm)

## **JSW Plastics Machinery, Inc.**

Head Office: 555 South Promenade Ave., Unit 104, Corona, California 92879, U.S.A.  
Phone: +1-951-898-0934 Fax: +1-951-898-0944  
Chicago Office: 1300 Landmeier Rd., Elk Grove Village, Illinois 60007, U.S.A.  
Phone: +1-847-427-1100 Fax: +1-847-427-1121  
Detroit Office: 24404 Catherine Industrial Drive, Suite 310 NOVI, Michigan 48375, U.S.A.  
Phone: +1-248-449-5422 Fax: +1-248-449-6018  
Atlanta Office: 1700 Cumberland Point Drive, Suite 17, Marietta, Georgia 30067, U.S.A.  
Phone: +1-770-952-0269 Fax: +1-770-956-9058

## **JSW Plastics Machinery (S) Pte Ltd**

Head Office: 17, Gul Lane, Jurong Town, Singapore 629413, Republic of Singapore  
Phone: +65-68614511 Fax: +65-68623166  
Philippine Office: Chemdis Bldg., Don Jesus Blvd., Alabang Hills Village, Muntinlupa City,  
Philippines  
Phone: +63-2-809-8982 Fax: +63-2-809-6221  
Indonesia Office: Jl. Palatehan Raya No.1-A, Kebayoran Baru, Jakarta 12160, Indonesia  
Phone: +62-21-725-7486 Fax: +62-21-725-7865

## **JSW Plastics Machinery (M) SDN. BHD.**

No.42, Jalan PJS 11/7, Bandar Sunway, 46150 Petaling Jaya,  
Selangor Darul Ehsan, Malaysia  
Phone: +60-3-56356453 Fax: +60-3-56356542

## **JSW Plastics Machinery (T) Co., Ltd.**

368/4, Soi Soonvijai 4, Rama IX Road, Bangkok, Huaykwang,  
Bangkok 10310, Thailand  
Phone: +66-2-369-4007 Fax: +66-2-369-4035

## **JSW Plastics Machinery Vietnam Ltd.**

Room 103, Techno-Center Thang Long Industrial Park Dong Anh District,  
Hanoi, Viet Nam  
Phone: +84-4-951-6383 Fax: +84-4-951-6384

## **JSW Plastics Machinery (H.K.) Co., Ltd.**

Room 907, Corporation Park, 11 On Lai Street, Sha Tin N.T., Hong Kong  
Phone: +852-2648-0720 Fax: +852-2686-8204

## **JSW Injection Machine Maintenance (Shenzhen) Co., Ltd.**

901, East, Dingxin Bldg., West Shahe Road,  
Nanshan District, Shenzhen, 518055, People's Republic of China  
Phone: +86-755-8602-0930 Fax: +86-755-8602-0934

## **JSW Plastics Machinery (Shanghai) Corp.**

29-D, Strength Plaza, No.600-3, Tianshan Road, Shanghai, 200051,  
People's Republic of China  
Phone: +86-21-5206-7031 Fax: +86-21-5206-7033

## **JSW Plastics Machinery (TAIWAN) Corp.**

Head Office: 1F., No.23, Da Hu 1st Rd., Guishan Shiang Taoyuan, Taiwan, R.O.C.  
Phone: +886-3-396-2102 Fax: +886-3-396-2104  
Tainan Office: 15 F-7, No.689-78, Shiau E. Rd., Yung Kang City, Tainan, Taiwan, R.O.C.  
Phone: +886-6-311-4192 Fax: +886-6-311-4193

