

## Performance Table

Module	Item	Model	JT40AD									
			20V			55V			110V			
Injection Unit	Screw cylinder type		K	A	B (OP)	K	A	B (OP)	K	A	B (OP)	
	Screw diameter	mm	18	20	22	25	28	32	32	35	40	
	Screw stroke	mm	65			90			110			
	Theoretical injection capacity	cm <sup>3</sup>	17	20	25	44	55	72	88	106	138	
	Injection capacity (GP-PS)	g	16	19	24	42	52	69	84	101	131	
	Standard	Injection pressure (Max.)	MPa {kgf/cm <sup>2</sup> }	222 {2260}	180 {1840}	149 {1520}	226 {2300}	180 {1840}	138 {1410}	215 {2190}	180 {1840}	138 {1410}
		Holding pressure (Max.)	MPa {kgf/cm <sup>2</sup> }	200 {2040}	162 {1650}	134 {1370}	203 {2070}	162 {1650}	124 {1260}	194 {1980}	162 {1650}	124 {1260}
		Injection speed	mm/s	300			270			160		
		Injection rate	cm <sup>3</sup> /s	76	94	114	133	166	217	129	154	201
		Plasticizing rate (GP-PS)	kg/h	14	18	22	20	25	30	30	40	50
		Screw speed	min <sup>-1</sup>	500			350			300		
	Low-inertia (HR) OP	Injection pressure (Max.)	MPa {kgf/cm <sup>2</sup> }	247 {2520}	200 {2040}	165 {1680}	251 {2560}	200 {2040}	153 {1560}	239 {2440}	200 {2040}	153 {1560}
		Holding pressure (Max.)	MPa {kgf/cm <sup>2</sup> }	222 {2260}	180 {1840}	149 {1520}	226 {2300}	180 {1840}	138 {1410}	215 {2190}	180 {1840}	138 {1410}
		Injection speed	mm/s	350			350			200		
		Injection rate	cm <sup>3</sup> /s	89	110	133	172	216	281	161	192	251
		Plasticizing rate (GP-PS)	kg/h	14	18	22	20	25	30	30	40	50
		Screw speed	min <sup>-1</sup>	500			350			300		
	High-speed (HS) OP	Injection pressure (Max.)	MPa {kgf/cm <sup>2</sup> }	247 {2520}	200 {2040}	165 {1680}	251 {2560}	200 {2040}	153 {1560}	—	—	—
		Holding pressure (Max.)	MPa {kgf/cm <sup>2</sup> }	222 {2260}	180 {1840}	149 {1520}	226 {2300}	180 {1840}	138 {1410}	—	—	—
		Injection speed	mm/s	550			500			—		
		Injection rate	cm <sup>3</sup> /s	140	173	209	245	308	402	—	—	—
		Plasticizing rate (GP-PS)	kg/h	14	18	22	20	25	30	—	—	—
Screw speed		min <sup>-1</sup>	500			350			—			
Clamping Unit	Nozzle touch force	kN {tf}	15 {1.5}			15 {1.5}			15 {1.5}			
	Nozzle stroke from platen	mm	20									
	Type of nozzle		Open nozzle									
	Cylinder temperature control		Cylinder: 3 / Nozzle: 2									
	Heater wattage	kW	2.8			5.1			7.1			
	Mechanism		Double toggle									
	Clamping force	kN {tf}	392 {40}									
	Daylight opening (Max.)	mm	550									
Miscellaneous	Opening stroke (Max.)	mm	250									
	Mold height	mm	200~300									
	Distance between tie-bars (DXW)	mm	360×535									
	Ejector point		5 points									
	Ejector force	kN {tf}	18 {1.8}									
	Ejector stroke	mm	40									
	Machine weight	t	3.1 (3.2)*			3.2 (3.3)*			3.4			
	Machine dimensions (LxWxH)	m	1.70×1.43×2.87			1.70×1.43×3.03			1.70×1.43×3.28			
Machine dimensions (HS) (LxWxH)	m	1.89×1.43×3.23			1.70×1.43×3.45			—				
Mold mounting plate height	mm	980										

### Remarks:

- Maximum injection pressure and maximum holding pressure may be restricted due to molding condition.
- The theoretical injection capacity is (cross sectional area of cylinder) x (stroke of screw).
- The injection capacity is applicable for GP-PS and variable according to the grade of resin, molding conditions and mold.
- The plasticizing rate is applicable for GP-PS.
- PC, HPVC, other engineering plastic, etc., low temperature setting and high speed molding may require a high torque depending on the grade or molding conditions. Please contact us if you plan.

### Note:

- Due to continual improvements, specifications are subject to change without notice.
- Actual figures of the specification will vary depending on final machine configuration. Please contact us if you require more specific data.
- Performance specifications are based on theoretical data.
- Low inertia injection specifications and high-speed injection specifications can be handled as option.
- Values in parentheses ( ) \* in the table are for high-speed injection specifications.
- Screw cylinder size B is optional.
- 7.1 MPa = 10.2 kgf/cm<sup>2</sup>, 1 kN = 0.102 tf

## Dimensions of Machine

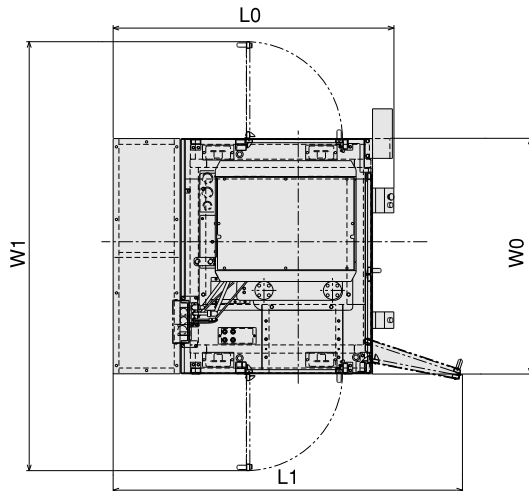

### Dimensions of machine

(Unit: mm)

Model	L0	L1	W0	W1	H		h	
					MIN.	MAX.		
JT40AD	20V	1700	2116	1425	2598	2300	2870	980
	20V-HR	1700	2116			2300	2870	
	20V-HS	1885	2301			2658	3228	
	55V	1700	2116			2456	3026	
	55V-HR	1700	2116			2456	3026	
	55V-HS	1700	2116			2882	3452	
	110V	1700	2116			2713	3283	
	110V-HR	1700	2116			2713	3283	

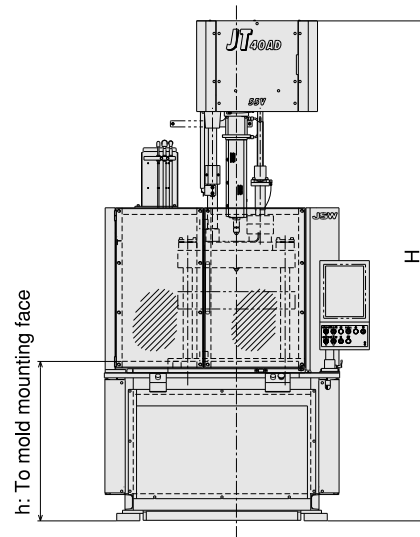
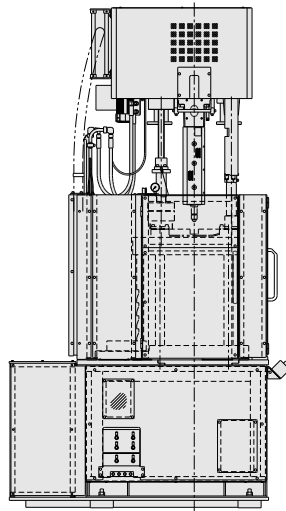

## Mold Related Dimensions

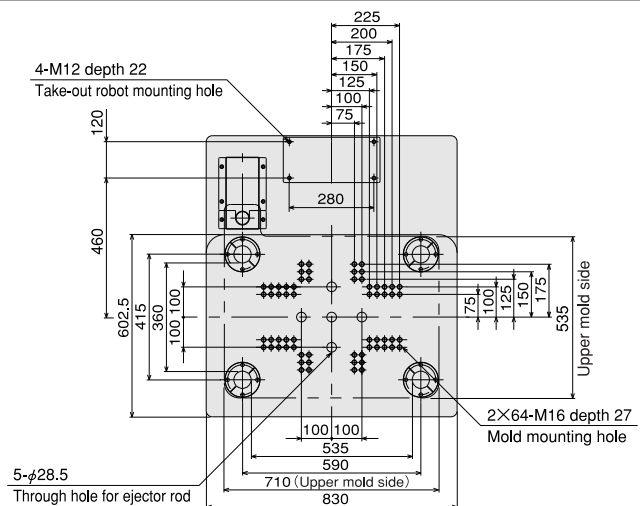
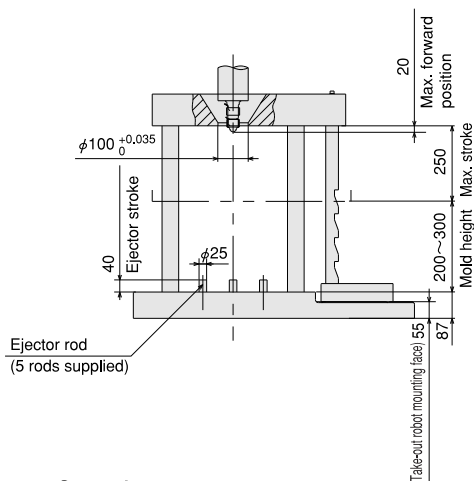

### Total Power Capacity

Machine Model	Injection unit	Total Power Capacity (kVA)		
		Standard Injection	Low-inertia Injection	High Speed Injection
JT40AD	20V	18.43	18.43	19.75
	55V	22.87	22.87	23.83
	110V	25.39	25.90	—

Note 1: The above incoming line size and main breaker capacity are values obtained by adding the capacity of molding machine unit to the capacity of mold thermal control/hydraulic unit, which is optional.  
 Note 2: We recommend that the rated interrupting current of the main power supply breaker is more than 25 kA at AC400V/460V.

### Capacity of Cooling Water (outline)

Model	Injection unit	Cooling Water Capacity for Barrel Temperature Control (m <sup>3</sup> /h)
		JT40AD
	55V	
	110V	

Note: The above figures do not include the required quantity of water for the mold temperature controller.

### Capacity of Air

Compressed air pressure	MPa	0.5
Compressed air necessity volume	NI/min	2