

JT-EM SERIES



Vertical-Type
Injection Molding Machines

JSW

A New Stage is set to open...

JSW's hi-tech integrity proven by this... High Performance Vertical-Type Injection Molding Machines.

With the latest technical expertise of satisfied needs based on the built-up of experiences and know-how, JSW is proud enough to show its offspring to the world – Vertical-Type Injection Molding Machines. As the result of improvements on operation, stability with speed and preciseness, space saving, robot and other automatic equipment interfaces and many others, JSW Vertical-Type Molding Machines now have user-friendly versatility and high performance. A new stage for the Injection Molding Machine is always set to open by JSW.



JT-EIII SERIES

In terms of safety improvements, the single-acting type machine comes with three-way safety protection as standard: hydraulic, electric and mechanical.

JT-REIII SERIES

Safety on the rotary-type machine is ensured by these three methods as standard: photocells electric and mechanical. The table features reciprocating rotation up to 180°.



Reliable Controller of Easy Handling and High Function.



■ SYSCOM2000T (standard equipment)

A large TFT color LCD screen (10.4 inch) has been equipped. This provides a clear picture for operator-friendly viewing. The dialog-type operation means that conditions can be set easily, simply by touching the location that requires setting.

■ High-touch Keyboard

Easy to handle design which arranged the mode selection keys on the illustrated machine of the operation panel. Easy setting prevents erroneous handling. (Storing 40 molds internally and on data card each.)

■ Built-in Controller

The control panel of the SYSCOM 2000T controller is installed in the local control box on the stationary platen. This eliminates unnecessary wasted space around the machine. The operator is able to command all operations of the machine while standing by the panel.

■ Print-out

With a printer connection, it is possible to keep records of molding conditions, measured data of various sorts and injection wave form.

■ Molding Condition Change (for Rotary type)

Two lower dies, delicately differs from each other in terms of their molding requirements. To conform, the requirements for either die (INJECTION, HOLDING PRESSURE, SCREW ROTATION) are made settable, independently.

SYSCOM2000T (Color LC Display)



▲ Overall Set-up Screen



▲ Injection Parameters Set Screen (Rotary type B mold settings)

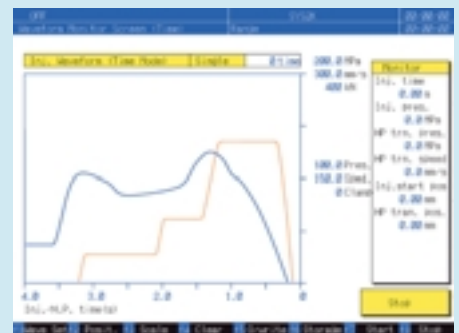

▲ Wave Form Monitoring Screen



▲ Action Monitor Screen

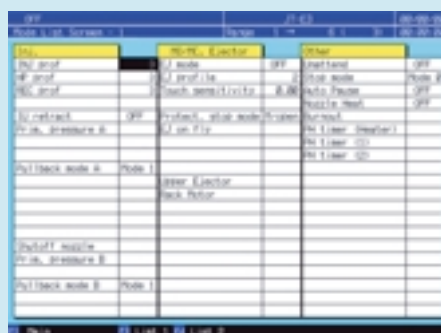

▲ Mode List Set Screen

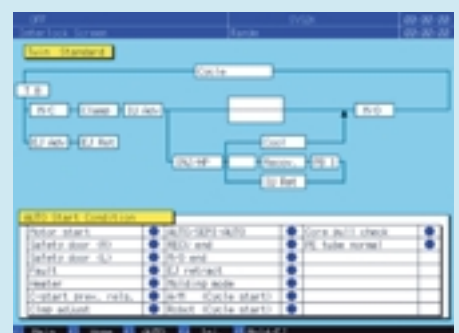

▲ Interlock Screen

Thoroughly and detailed investigation realize stable high precise molding.

■N2000F Cylinder (standard equipment)

Newly developed high wear and corrosion-resistant bimetallic cylinder N-ALOY®N2000F is a lining material which is based on high nickel content alloy containing hard tungsten carbide through dispersion. As compared with the conventional N60S, it has higher resistance to abrasion and affords stable injection molding of glass fiber filled, flame retardant filled plastics and super engineering plastics, moreover extends the service life of the cylinder.

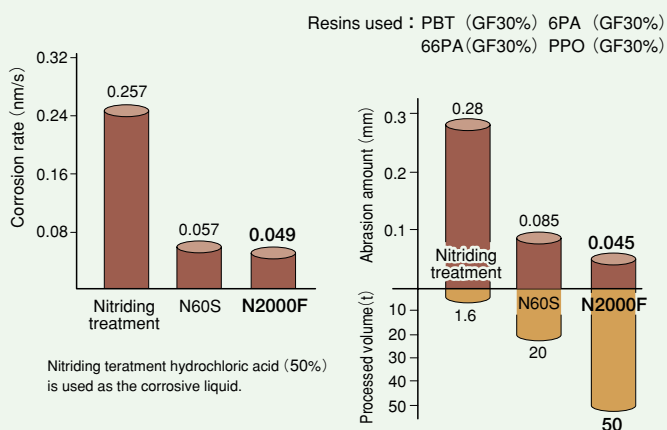
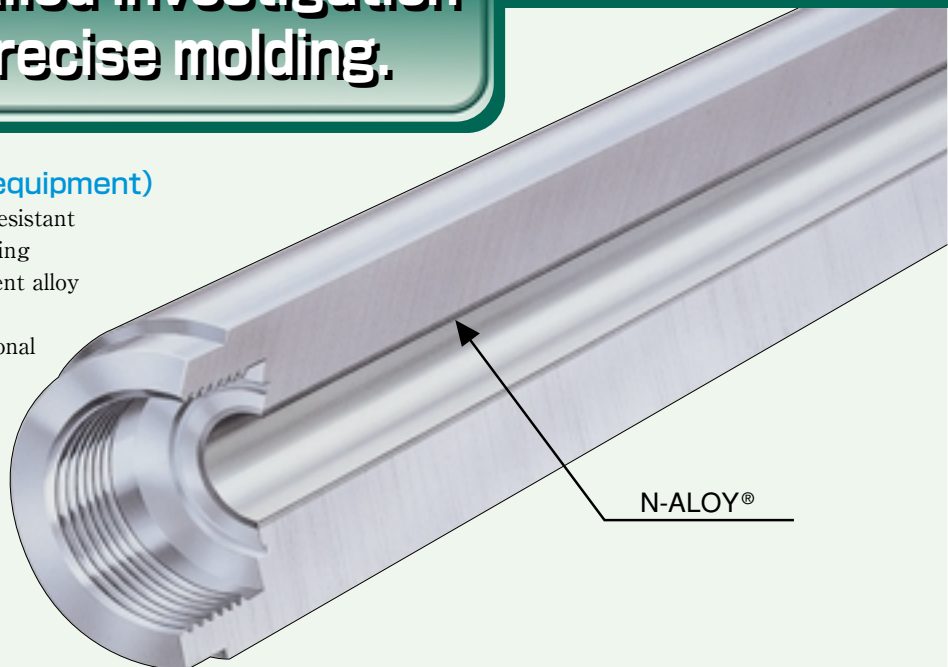

■Oil Temperature Stabilizer

The unit automatically controls the tank oil temperature as well as the return line from actuator and drain line from the pump by detecting the operating temperature of the oil and maintaining optimum condition, so molding stability can be improved. (Patent)



■“IVS Control” Holding Pressure Changeover

Changeover to holding pressure is done by sensing the screw speed slowdown immediately before cavity filling. As compared with the conventional methods, fluctuations of shot weight are reduced by half, making the system quite suitable for precision molding.

■S50 Screw (standard equipment)

JSW's own High-hardness alloy. Having an outstanding high wear resistance, a fullflight S50 screw is a new development realizing a fast cycle molding.



■HT Screw Head (standard equipment)

This HT screw head is useful for stabilizing parts weight. As compared with the conventional screw heads, the clearance between the cylinder and check ring is decreased to the minimum, so that the back flowing resin is decreased to the minimum.



■PID Temperature Control / Nozzle Temperature Control (SSR)

By the quick response to temperature changes, overshooting is reduced to ensure precise temperature control. As a SSR (solid state relay) is adopted for the nozzle section, deviations of actual temperatures from the setting are eliminated to provide stable temperatures at all time.

Safety / Operationality upgrading. Energy / Space saving. These two tasks are made compatible.



■ Mold Access in Three Directions

Furnished with a larger, fully openable safety door on each of the three sides, mold can be easily set mounted on either of the three sides : frontal (or operating), left and right. The better working efficiency is ensue. Connecting of auxiliary equipment becomes easier. The table's rotation is a reciprocating rotation at 180°.

■ Tip Nozzle (standard equipment)

In contrast to the conventional open nozzle structure, this new type consists of a tip nozzle and an adaptor. The advantages are : an easy replacement of the tip nozzle and an enlargement of molding conditions.



■ Screw Cylinder Slider

The screw cylinder can be mounted or removed by one person quickly and safely. (Patent)

■ Nozzle Touch Control

A nozzle touch level can be automatically set at a single touch. This eliminates any possible work at a high ground, and so in safety the position of the nozzle touch can be maintained. (Patent)

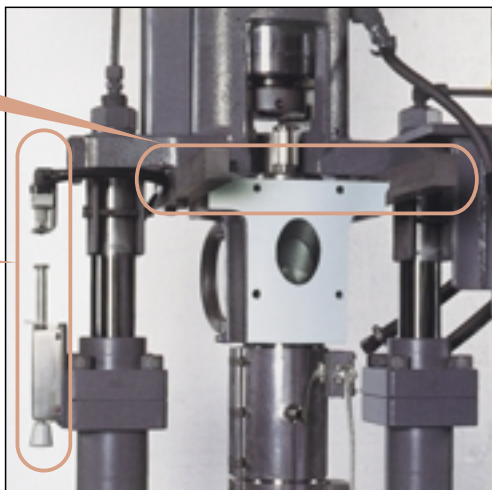

■ Safety Door, Electric and Hydraulic with Mechanical Safety Device (Single acting type)

In addition to the electrical safety device, hydraulic safety device and mechanical safety device goes into action three together, in order to ensure safety of the operator.



■ Safety Door, Electric, Photocell and Mechanical Safety Device (Rotary type)

In addition to the electrical safety device, photocell safety device and mechanical safety device goes into action three together, in order to ensure safety of the operator.



Energy / Space saving

■ Load-Match System

An injection molding machine's power consumption is approx. 90% attributable to its hydraulic pump. JSW has opted for a load-mach sysytem under which the built-in controlled variable will trigger off a minor feedback effect. Thus, there have achieved both the improved stability of pressure and velocity and the conservation of energies.

■ Space Saving

By eliminating the conventional control panel's spread out, as well as by rearranging the hydraulic unit and other component devices, the largest possible space has benn assured. Compared with the conventional machine, the installation space has been reduced by 15%.

A Wide Selection

Block Systems

JT-EIII series has various modules ready for use. The size, shape, production run and mode of a molding part will select the most opportune specification and viable performance of an injection molding machine currently available, resulting in a precise, steady and enhanced molding production.

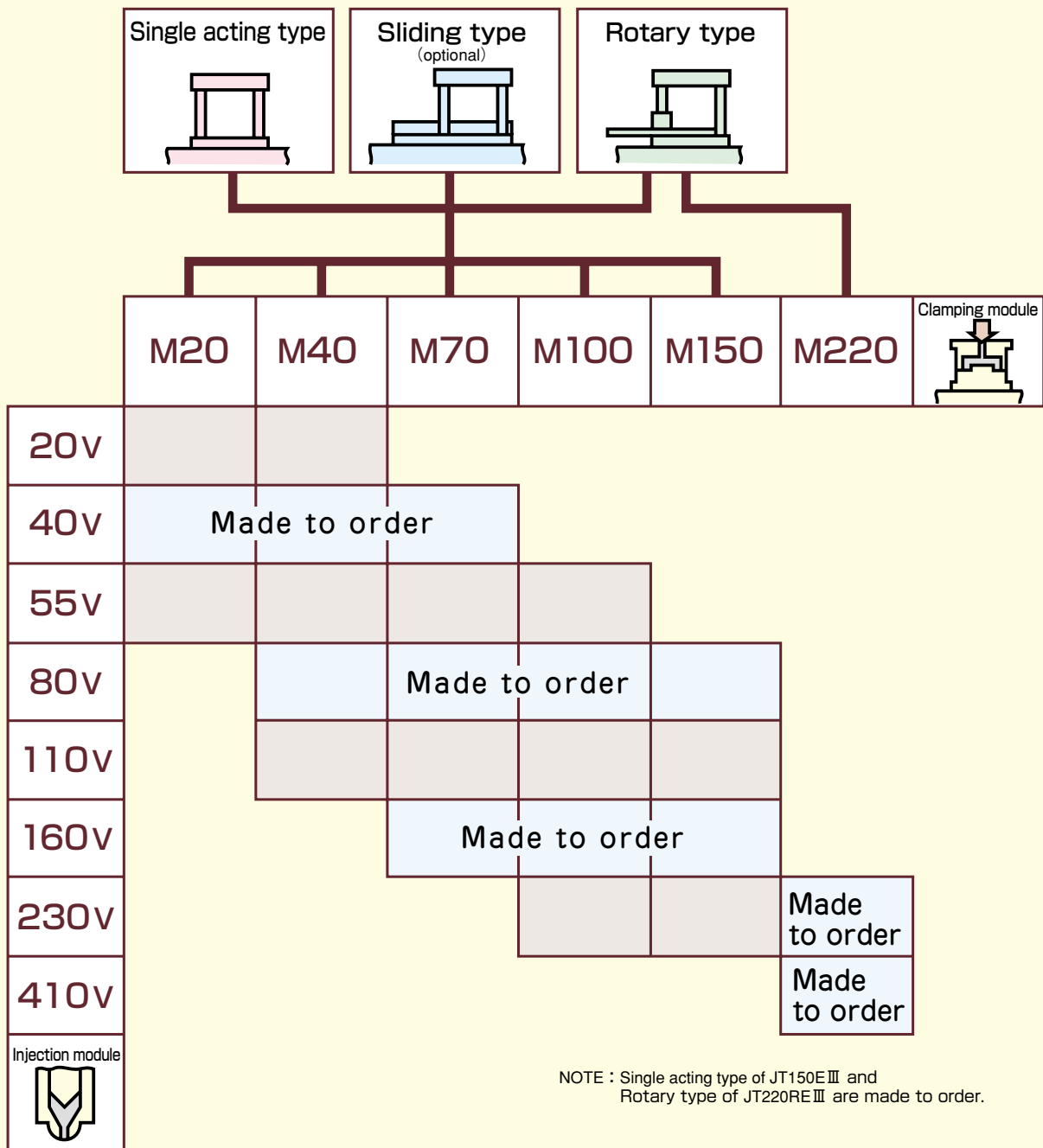

NOTE : Single acting type of JT150EIII and Rotary type of JT220REIII are made to order.

Injection Module

Module #	20V			40V (made to order)			55V			80V (made to order)			110V			160V (made to order)			230V			410V (made to order)		
	K	A	B	K	A	B	K	A	B	K	A	B	K	A	B	K	A	B	K	A	B	K	A	B
Screw diameter mm	18	20	22	22	25	28	25	28	32	28	32	35	32	35	40	35	40	45	40	45	50	46	53	58
Injection pressure MPa (kgf/cm ²)	228 {2320}	184 {1880}	152 {1555}	238 {2430}	184 {1880}	147 {1500}	228 {2330}	182 {1860}	139 {1420}	241 {2460}	185 {1890}	155 {1580}	218 {2220}	182 {1860}	139 {1420}	237 {2420}	181 {1850}	143 {1460}	228 {2320}	179 {1830}	145 {1480}	237 {2420}	178 {1820}	149 {1520}
Theoretical injection capacity cm ³	16	20	25	28	37	46	44	55	72	61	80	96	88	106	138	125	163	206	182	230	285	307	407	488
Injection rate cm ³ /s	35	43	53	48	62	78	50	63	82	66	87	104	74	88	115	87 (78)	114 (102)	144 (129)	91 (81)	115 (103)	142 (127)	138 (115)	185 (154)	222 (185)
Plasticizing rate kg/h	14	18	22	22	20	25	20	25	30	25	30	40	30	40	50	40 (30)	50 (39)	63 (48)	50 (40)	63 (50)	73 (57)	70 (58)	100 (83)	125 (104)
Screw speed min ⁻¹	50~550			50~515			25~315			25~300			25~290			25~260(25~230)			25~200(25~180)			25~220(25~183)		
Pump driving motor kW	5.5			7.5			7.5			11			11			15			15			22		
Heater wattage kW	2.8			4.1			5.0			6.4			7.6			9.8			12.0			13.1		
Cooling water consumption m ³ /h	0.3			0.3			0.3			0.4			0.4			0.4			0.4			1.2		

- NOTES : (1) Numerical values in () as per 160V, 230V and 410V signify that they are applicable for 50Hz power source. The rest are for both the 50Hz and 60Hz power source.
(2) The plasticizing rate is applicable for polystyrene.
(3) B size screw is optional.
(4) 40V, 80V, 160V and 410V made to order.
(5) 1MPa=10.2kgf/cm²

Clamping Module

Type	Single acting type					Sliding type (optional)					Rotary type					
	M20	M40	M70	M100	M150 (made to order)	M20S	M40S	M70S	M100S	M150S	M20R	M40R	M70R	M100R	M150R	M220R (made to order)
Clamping force kN {tf}	196 {20}	392 {40}	686 {70}	981 {100}	1470 {150}	196 {20}	392 {40}	686 {70}	981 {100}	1470 {150}	196 {20}	392 {40}	686 {70}	981 {100}	1470 {150}	2160 {220}
Mold opening force kN {tf}	35 {3.6}	35 {3.6}	60 {6.1}	60 {6.1}	60 {6.1}	35 {3.6}	35 {3.6}	60 {6.1}	60 {6.1}	60 {6.1}	35 {3.6}	35 {3.6}	60 {6.1}	60 {6.1}	60 {6.1}	94 {9.6}
Daylight opening mm	420	470	550	630	730	350	400	480	560	660	370	400	500	550	600	700
Opening stroke mm	250	270	300	330	380	250	270	300	330	380	200	200	250	250	250	350
Min. mold height mm	170	200	250	300	350	100	130	180	230	280	170	200	250	300	350	350
Mold size (Max.) or Distance between tie-bars mm	310×310	360×360	410×410	460×460	510×510	300×330	350×400	400×440	450×500	500×550	300×300	330×330	380×380	430×430	480×480	560×560
Hydraulic ejector	5 points				5 points	1 point					1 point				3 points	
Ejector force kN {tf}	34 {3.5}				34 {3.5}	18 {1.8}		26 {2.7}			18 {1.8}		26 {2.7}		42 {4.3}	
Ejector stroke mm	40		60		60	40		60			40		60		100	
Hydraulic oil reservoir L	170				170	170					170				300	

- NOTES : (1) Sliding type is optional.
(2) Single acting type of JT150E III and Rotary type of JT220RE III are made to order.
(3) 1kN=0.102tf

Machine Dimensions

Single acting type

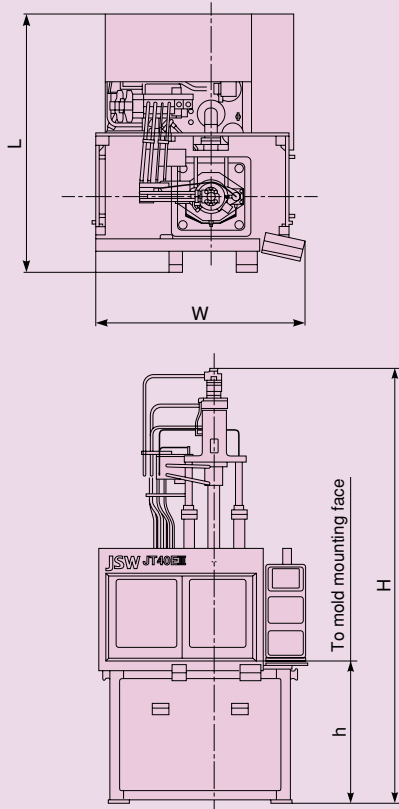

unit : m

Model	L	W	H		h	Machine weight (t)	
			MAX	MIN			
JT20E III -	1.8	1.5	20V	2.9	2.4	1.033	2.6
			40V※	3.0	2.5		2.7
			55V	3.1	2.6		2.7
JT40E III -	1.9	1.5	20V	3.0	2.5	1.053	2.7
			40V※	3.1	2.6		2.8
			55V	3.2	2.7		2.8
			80V※	3.4	2.8		2.8
JT70E III -	2.0	1.5	110V	3.5	2.9	1.193	2.9
			160V※	3.4	2.7		2.9
			40V※	3.4	2.7		3.0
			55V	3.5	2.9		3.0
JT100E III -	2.0	1.7	80V※	3.6	3.0	1.283	3.1
			110V	3.7	3.1		3.1
			160V※	3.9	3.3		3.3
			230V	3.7	3.0		3.5
			55V	3.8	3.1		3.5
JT150E III -	2.1	1.8	80V※	3.9	3.2	1.458	3.6
			110V	4.1	3.4		3.8
			160V※	4.2	3.6		3.9
			230V	4.1	3.3		4.2
							4.3
							4.5
							4.6

※Made to order

Rotary type

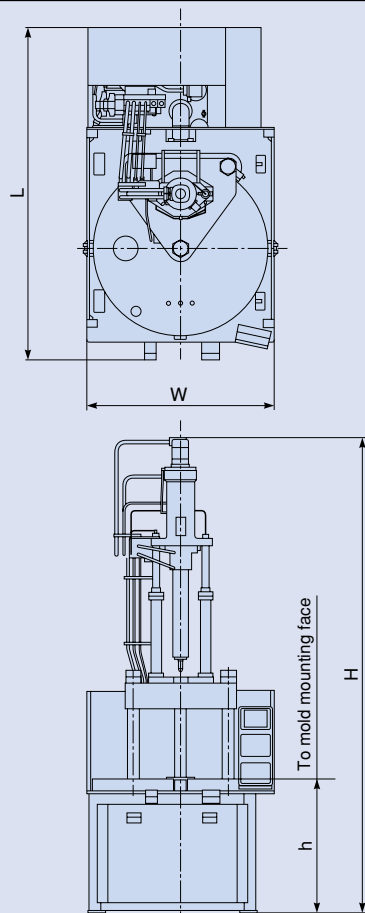

unit : m

Model	L	W	H		h	Machine weight (t)	
			MAX	MIN			
JT20RE III -	2.4	1.4	20V	2.8	2.4	0.953	3.3
			40V※	2.9	2.5		3.4
			55V	3.0	2.6		3.4
JT40RE III -	2.5	1.4	20V	2.6	2.4	0.953	3.5
			40V※	2.9	2.5		3.6
			55V	3.0	2.6		3.6
			80V※	3.1	2.7		3.6
JT70RE III -	2.7	1.4	110V	3.3	2.8	1.053	3.7
			160V※	3.7	3.2		4.1
			40V※	3.1	2.7		4.0
JT100RE III -	2.8	1.5	55V	3.2	2.7	1.088	4.1
			80V※	3.3	2.9		4.1
			110V	3.5	3.0		4.2
			160V※	3.7	3.2		4.4
JT150RE III -	3.0	1.6	230V	3.4	2.8	1.148	4.8
			55V	3.5	3.0		4.8
			80V※	3.6	3.1		4.9
			110V	3.8	3.3		5.1
JT220RE III -	3.4	1.7	160V※	4.0	3.4	1.378	5.2
			230V	4.1	3.5		5.8
			410V※	4.4	3.7		5.9
							6.1
							6.2
							7.8
							8.0

※Made to order

Mold Dimensions and Relative Equipment.

Single acting type

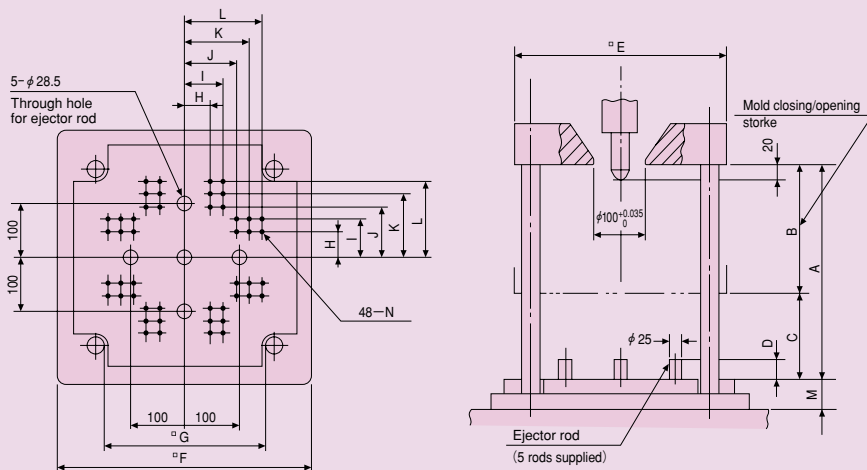

unit : mm

Model	A	B	C	D	E	F	G	H	I	J	K	L	M	N
JT20E III	420	250	170	40	410	500	310	50	75	100	125	150	60	M12×22
JT40E III	470	270	200	40	480	570	360	75	100	125	150	175	60	M16×27
JT70E III	550	300	250	60	565	650	410	75	125	150	175	200	60	M16×27
JT100E III	630	330	300	60	635	720	460	100	150	175	200	225	60	M16×27
JT150E III	730	380	350	60	715	800	510	125	175	200	225	250	60	M16×27

Nozzle sizes

SVO Nozzle

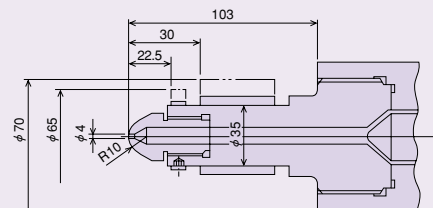

Shut-off Nozzle (optional)

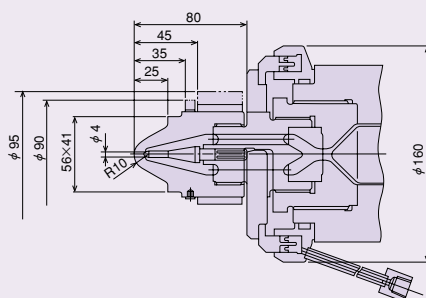

Rotary type

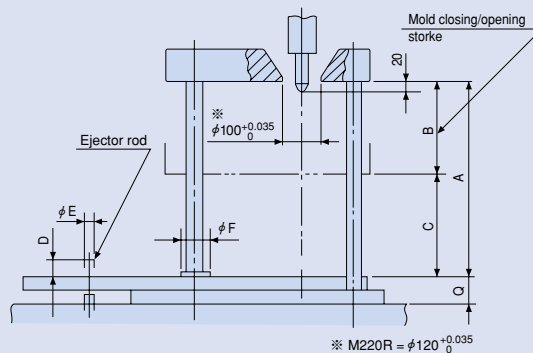
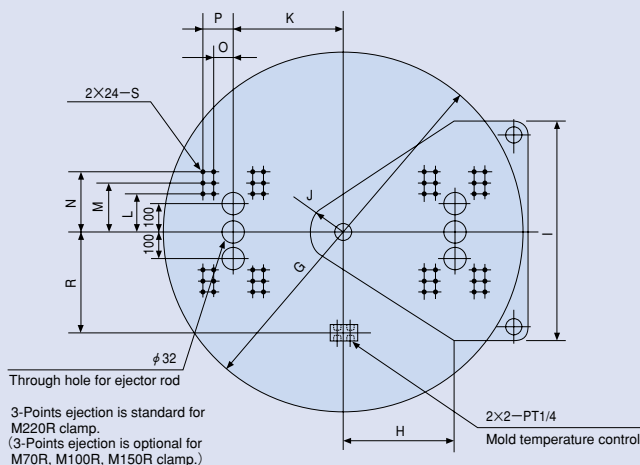

unit : mm

Model	A	B	C	D	E	F	G	H	I	J	K	L	M	N	O	P	Q	R	S	Mold weight
JT20RE III	370	200	170	40	20	160	910	265	570	85	280	100	125	150	50	75	95	235	M12×22	150kg×2
JT40RE III	400	200	200	40	20	170	1030	305	650	90	320	125	150	175	75	100	95	265	M16×27	225kg×2
JT70RE III	500	250	250	60	25	180	1160	340	745	100	360	150	175	200	75	125	95	315	M16×27	300kg×2
JT100RE III	550	250	300	60	25	196	1310	380	835	105	405	175	200	225	100	150	95	355	M16×27	400kg×2
JT150RE III	600	250	350	60	25	240	1490	440	945	110	465	200	225	250	125	175	105	345	M16×27	500kg×2
JT220RE III	700	350	350	100	25	240	1540	265	940	105	435	200	225	250	125	175	110	360	M16×27	690kg×2

Standard Equipment

Optional Equipment

■ Standard Equipment

Unit item		
Injection and Plastivating Unit	Open nozzle (tip type)	
	Wear and corrosion-resistant cylinder ①	
	Wear and corrosion-resistant screw ①	
	HT Screw head	
	Screw cylinder slider ★	
	Cold start-up prevention	
	Mold-Pause changeover function	
	Automatic purging circuit	
	Automatic setting of nozzle touch position ★	
	Nozzle transfer control timing select	
	Suck back timing select	
	Injection and rotation program control	Injection speed 1 - 6 steps (adjust.)
		Injection pressure
		Holding pressure
		Screw speed 1 - 3 steps (adjust.)
		Screw back pressure (adjust.)
	Suck back	
	Transfer to holding pressure by sensing injection speed (IVS)	
	Shift injection profile ★	
	Cylinder temperature remote setting (PID)	
	Nozzle temperature control (SSR)	
	Molding condition change (for Rotary type only)	
	Mold Clamping Unit	Self-lubricating tie-bar bushings
Remote setting of mold open/close speed		
Remote setting of moving platen position		
Remote setting of ejector speed		
Remote setting of ejector position		
Remote setting of mold clamping force		
Clamping force holding circuit		
Mold protection device		
Mold thickness abnormal alarm (Min. thickness)		
Safety device		Electric/Mechanical
		Photocell (for Rotary type only)
		Hydraulic (for Single acting type only)
Remote setting of table rotation speed		
Automatic greasing of rotating mechanism (for Rotary type only)		
Hydraulic Unit and Related Equipment	Load-match system	
	Oil preheating circuit	
	Oil temperature stabilizer/cooling circuit ★	
	Oil filter	
	Oil temperature alarm/upper and lower limits	
	Return filter clogging alarm	
	Solenoid valves with indication lamp	
	Mold cooling water closed circuit	

Unit item		
Controller	SYSCOM controller display (touch panel TFT color LCD)	
	Memory of molding conditions (internal memory 40 molds)	
	Data card (40 molds/card)	
	Printer output terminal ②	
	Self-diagnostic function	
	Overall set screen	
	Molding support function (Basic system)	
	Time clock	
	Unmanned operation switch	
	Monitor	Cylinder temperature monitoring function
		Heater circuit break
Injection pressure monitor (IPM)		
Injection wave form monitor		
Injection wave form memory		
Statistical graph display		
Table display		
Display of mold temperature ③		
Abnormal alarm buzzer		
Production monitoring ④		
Operating time display		
Action monitor		
Molding condition upper/lower limit ⑤		
Maintenance ⑥		
Alarm history		
Set value history		

★ : Patent

NOTES:

- ① Either of the A or K size are standard specification. (B size will be optional)
- ② The printer, printer cable, and receptacle are optional.
- ③ Sensor and cable are not included.
- ④ Setting of production quantity and advance notice are possible and completion time is displayed.
- ⑤ Monitoring functions of the following particulars are equipped as standard. (Cycle time, Injection time, Rotation time, Cushion, Injection start point, Changeover Position to holding pressure, Injection pressure, Changeover pressure to holding, Mold opening-closing time, Screw back pressure.)
- ⑥ Maintenance service time and areas are displayed.

Optional Equipment

	Item	Single acting	Rotary	Injection
1	B size screw cylinder			○
2	SVO long nozzle			○
3	High-melter MII screw			○ (1)
4	LCP screw (only for LCP resin use)			○ (2)
5	Cylinder heat insulation cover			○
6	Shut-off nozzle (pneumatic)			○
7	Hopper flange temperature control			○
8	Accumulator injection			○
9	Injection rate increase			○
10	KC nozzle			○
11	Special screw head			○
12	Molding device for thermosetting resin	○ (3)	○ (3)	○ (3)
13	Hopper			○
14	Daylight extension	○	○	
15	Ejector stroke extension	○	○	
16	Ejector for upper mold	○	○	
17	Ejector for 3-points ejection		○ (4)	
18	Mold platen heat insulation board	○	○	
19	Air jet	○	○	
20	Unscrewing motor control circuit	○	○	
21	Hydraulic core puller circuit	○	○ (5)	
22	Pneumatic core puller circuit	○	○	
23	Dual function (Lower mold ejection during mold closing)		○	
24	Dual function (Upper mold ejection during table rotation)		○	
25	Oil low level alarm	○	○	
26	Suction filter clogging alarm	○	○	
27	Low pressure injection circuit	○	○	
28	Flow indicator for cooling water	○	○	
29	Mold temperature control piping		○	
30	Cooling water cut off alarm	○	○	
31	Vibration proof rubbers	○	○	
32	Die clamber	○	○	
33	Mold quick set-up device	○	○	
34	Take-out robot mounting holes	○	○	
35	Easy die clamp	○	○	
36	Sliding type equipment	○		
37	Mold positioning	○	○	
38	Single acting type 150t clamping unit	○		
39	Anchor bolt	○	○	
40	Calendar timer	○	○	

	Item	Single acting	Rotary	Injection
41	Leakage breaker	○	○	
42	Mold temperature indicator	○	○	
43	Alarm light	○	○	
44	Mold heater circuit	○	○	
45	Take-out robot interface	○	○	
46	Spare plug receptacle	○	○	
47	Speare output signal circuit	○	○	
48	Communication function with host computer	○	○	
49	Printer (with printer cables)	○	○	
50	Printer cable (IBM compatible type)	○	○	
51	Data card (40 molds/card)	○	○	

NOTES:

- (1) Available for screw size larger than ϕ 35.
- (2) Available for screw size ϕ 28 and smaller.
- (3) Not applicable for M20 (S,R) ,20V.
- (4) Only for rotary type.
Not applicable for M20R and M40R.
- (5) Not applicable for lower mold of M20R.

JSW THE JAPAN STEEL WORKS, LTD.

URL <http://www.jsw.co.jp/>

Division : J-Tower, 1-1, Nikko-cho, Fuchu-shi, Tokyo 183-8503, Japan
Head Quarter : Phone : +81-42-330-8008 Fax : +81-42-330-8023
URL http://www.jsw.co.jp/inj_f/inj_index.htm

Branch Offices : Osaka, Fukuoka, Nagoya, Hiroshima, Sapporo

Plants : Muroran, Hiroshima, Yokohama

Düsseldorf Office : Friedrichstr. 19, 40217 Düsseldorf, F.R, Germany
Phone : +49-211-3116660 Fax : +49-211-31166640

Teheran Office : Gandi Ave., Corner of Street No.18, Bldg. No.72, Apartment
No.5, Second Floor, Postal Code 15179, Teheran, I.R. of Iran
Phone : +98-21-8776685 Fax : +98-21-8791199 Telex : 213057 (JSW IR)

Singapore Office : 16 Raffles Quay, #27-01C, Hong Leong Bldg., Singapore 048581,
Republic of Singapore
Phone : +65-62206227 Fax : +65-62240726

Beijing Office : 5, Dong Sanhuan Bei-lu, Chaoyang District, Beijing,
Beijing Fortune Bldg., Room No. 907, People's Republic of China
Phone : +86-10-6590-8966 Fax : +86-10-6590-8968

JSW Plastics Machinery, Inc.

Head Office : 555 South Promenade Ave., Unit 104 Corona, California 92879, U.S.A.
Phone : +1-909-898-0934 Fax : +1-909-898-0944

Detroit Office : 24404 Catherine Industrial Drive, Suite 310 NOVI, Michigan 48375, U.S.A.
Phone : +1-248-449-5422 Fax : +1-248-449-6018

Atlanta Office : 1700 Cumberland Point Drive, Suite 17, Marietta, Georgia 30067, U.S.A.
Phone : +1-770-952-0269 Fax : +1-770-956-9058

JSW Plastics Machinery (S) Pte Ltd

Head Office : 17, Gul Lane, Jurong Town, Singapore 629413, Republic of Singapore
Phone : +65-68614511 Fax : +65-68623166

Philippine Office : Chemdis Bldg., Don Jesus Blvd., Alabang Hills Village, Muntinlupa City,
Philippines
Phone : +63-2-809-8982 Fax : +63-2-809-6221

Indonesia Office : Jl. Palatehan Raya No.1-A, Kebayoran Baru, Jakarta 12160, Indonesia
Phone : +62-21-725-7486 Fax : +62-21-725-7865

JSW Plastics Machinery (M) SDN. BHD.

No.42, Jalan PJS 11/7, Bandar Sunway, 46150 Petaling Jaya,
Selangor Darul Ehsan, Malaysia
Phone : +60-3-56356453 Fax : +60-3-56356542

JSW Plastics Machinery (T) Co., Ltd.

496/111-112, Sathupradit Road, Bangpongpan, Yannawa,
Bangkok 10120 Thailand
Phone : +66-2-682-2011 Fax : +66-2-682-2015

JSW Plastics Machinery (H.K.) Co., Ltd.

Room 907, Corporation Park,
11 On Lai street, Shatin N.T., Hong Kong
Phone : +852-2648-0720 Fax : +852-2686-8204

JSW Injection Machine Maintenance (Shenzhen) Co., Ltd.

Ping An North Rd., Songgan Town, Baoan, Shenzhen,
Guangdong, People's Republic of China
Phone : +86-755-2709-7116 Fax : +86-755-2709-7052

JSW Plastics Machinery (Shanghai) Corp.

Room 618, Tomson Commercial Bldg., 710 Dongfang Rd., Pudong, Shanghai, 200122,
People's Republic of China
Phone : +86-21-5830-2191 Fax : +86-21-5830-2193

JSW Plastics Machinery (TAIWAN) Corp.

Head Office : 1st. Floor, No.63, Wenhua 3rd. Rd., Gueishan Shiang Taoyuan,
Taiwan, R.O.C.
Phone : +886-3-396-2102 Fax : +886-3-3962-2104

Tainan Office : 15Fl.-7, No.689-78, Shiau E. Rd., Yungkuang City, Tainan, Taiwan, R.O.C.
Phone : +886-6-3114192 Fax : +886-6-3114193