

# History and Future Prospects of Rolling Stock Parts

Teruyuki Aida Yusuke Nishimi Atsunori Yamaguchi Noriaki Oonuma

## —Synopsis—

The rolling stock is common vehicle in the world and is mass transportation means of passengers and goods in safety. For many years, JSW has produced and sold the couplers and the draft gears, which are the important parts of the rolling shock. Now, JSW is the leading manufacture of these products in Japan. Especially for the draft gear, we developed the Double-Construction Rubber Draft gear, which can absorb the impact in anteroposterior direction and improve passengers comfort while vehicle is moving. This double-construction rubber draft gears are now adopted for all newly manufactured trains of the domestic railroad companies. As for the Tokyo metropolitan area, most of all the trains are equipped with these draft gears.

We describe here the history of our products, the rolling stock parts, and future prospects as well.

## 1. Introduction

JSW's involvement with railway products dates back to the prewar era. Unlike JSW's recent product lines that specialize in two products: couplers and draft gears, JSW used to handle various products from parts for axles, wheel centers, carriages and electric locomotives to hydraulic pumps and motors, axles and brake discs in addition to couplers and draft gears as described in the Japan Steel Works History.

The background of JSW's first involvement in railway products is not clear, but it is not hard to assume that JSW dealt with railway products from the beginning of its history, considering the founding history of dealing with national policy-based products at the time.

The couplers and draft gears are always installed at two ends of the car as shown in Fig. 1. The couplers are "devices to connect and release cars", and the draft gears are "devices to absorb and reduce longitudinal impact during travel" which are connected with a pin joint at the tail end of the couplers, both of which are essential parts for cars.

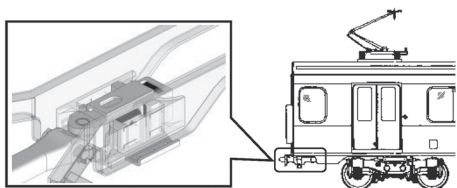

Fig. 1. Installation Areas of Couplers and Draft Gears

For the couplers, production of parallel-type automatic couplers (Shibata style) began in 1950 as JSW's first-made device, while production of the draft gears started around 1957 with spiral spring draft gears. Thus, as a leading manufacturer of couplers and draft gears in Japan, JSW has been producing new products that meet customers' needs, and has been retaining the domestic market share mainly through wide product adoption in Japan National Railways and private railway companies.

This document describes the history of couplers and draft gears as well as JSW's efforts from the launch of railways in Japan to today, and also explains future prospects of railway products.

## 2. Transition of couplers and draft gears, and JSW's effort

### 2.1 History of couplers

Everyone has seen couplers between cars from station platform once; however, couplers back in the day in Japan used to be in significantly different shapes. When the domestic railway between Shinbashi and Yokohama launched in 1872, a screw type coupler was adopted.

As shown in the upper part of Photo 1, the screw type couplers were composed of a link with a screw mechanism that transfers tensile force at the center, and draft gears to receive compression force on the right and left sides.

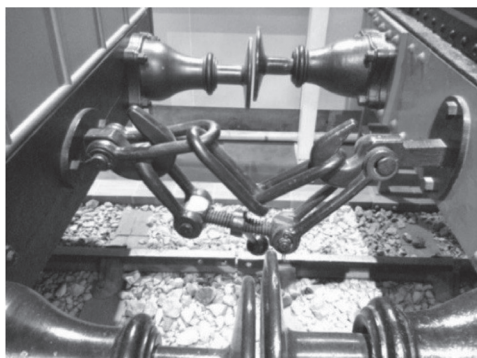

Photo 1. Screw Type Coupler and Uncoupling Operation  
(Reference: Sited from "Couplers" in Wikipedia)

When coupling cars, an operator entered between the car ends, set a tension rod with a threaded hook between the cars, and tightened the thread in order to stretch the draft gears on the both sides. (Photo 1, bottom) This procedure was extremely dangerous and accidents used to occur constantly at the time. Furthermore, the screw type couplers depended on human power for the coupling and uncoupling procedures; therefore, increasing the size was difficult and only handheld parts were mounted, which limited pulling capability.

The screw type couplers were used widely in the railways in Japan at the time because the British-based technology had been adopted. On the other hand, automatic couplers were adopted in the United States. Research and studies towards accepting automatic couplers were conducted in Japan to improve safety for the coupling/uncoupling procedures and transportation capacity. As a result, in 1925, a switchover from the screw type couplers to the automatic couplers was launched simultaneously nationwide. This history led to the following advancement of railways in Japan.

#### (1) Automatic coupler

JSW entered the coupler markets in 1950 by beginning its production and sales of parallel-type automatic couplers (hereinafter referred to as automatic couplers) that were modified forms of automatic couplers adopted in the United States. This automatic coupler model maintains its original shape even today, although the form was altered in 1968 by utilizing newly developed cast steel for improved strength. The automatic coupler shown in Photo 2 is currently used mainly for locomotives and freight cars.

The automatic coupler features a form that allows for mutual car coupling and that also allows to pass through curves and hills comfortably by creating gaps at the coupling surface (Fig. 2). Because a long, heavyweight train cannot be pulled all at once, these gaps help disperse tensile force generated from locomotives and are essential in enabling vertical and horizontal swing. On the contrary, gaps with formation cars are detrimental when there are tensile and compression forces which cause large impact during towing.

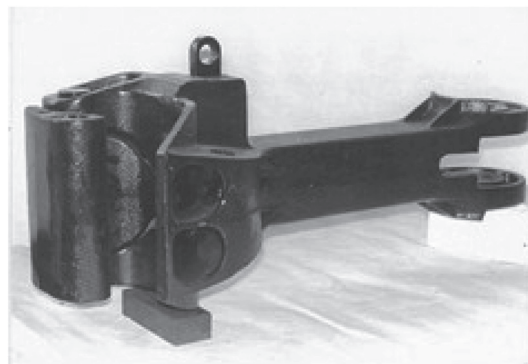

Photo 2. Automatic Coupler (with a Pin)

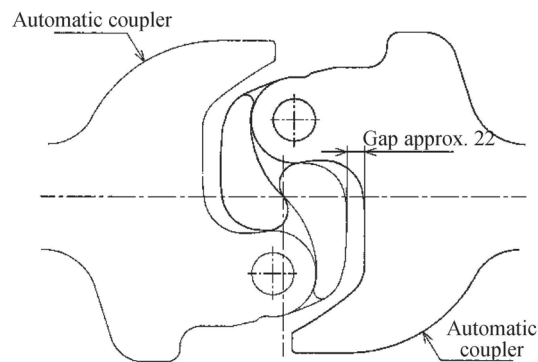

Fig. 2. Coupling Form of the Automatic Coupler  
(Gap at the Coupling Surface)

(2) Tight lock-type automatic coupler

In order to compensate for these shortcomings of the automatic couplers, JSW developed a tight lock-type automatic coupler in 1958 for a passenger transportation purpose.

The series was named the NCA-type and NCB-type with lineups ranging from large models to compact models, and used depending on whether they were passenger cars or diesel multiple units. (Photo 3)

For the tight lock-type automatic coupler, the coupling surface form shown in Fig. 3 is designed to achieve tight contact without gaps at the coupling surface, unlike the automatic couplers. This mechanism is composed of a lock, knuckle and inclined plate as shown in Fig. 4. The lock works as a locking mechanism by fitting between the knuckle and inclined plate, and constantly sliding down along the surface of the inclined plate. Therefore, even when the device wears away, the lock slides down constantly which prevents gaps from being formed. Consequently, this mechanism has been adopted for passenger carrying cars (sleeping carriages, trains and diesel multiple units) where comfort is sought.

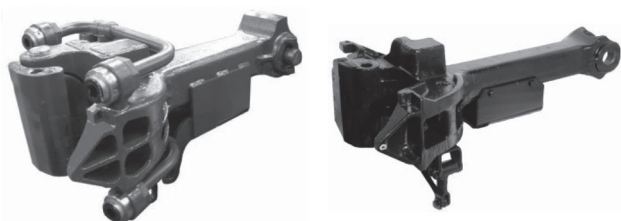

Photo 3. NCA5- and NCB2-Type Tight Coupler

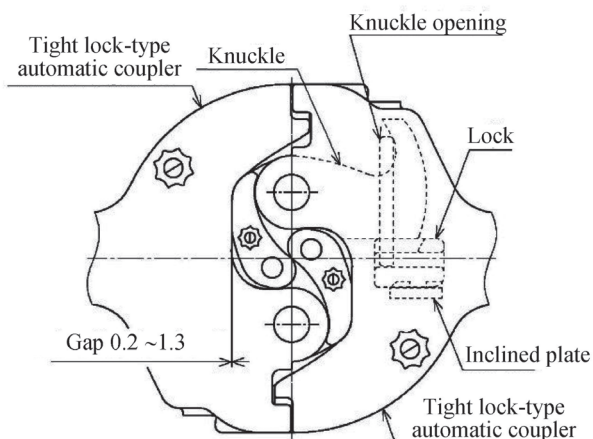

Fig. 3. Coupling Form of the Tight Lock-Type Automatic Coupler

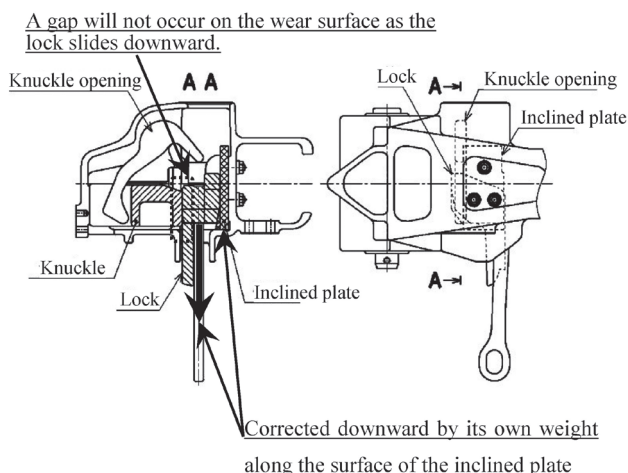

Fig. 4. Mechanism of TightLock-Type Automatic Coupler

In recent years, however, demand for this mechanism has been on a declining trend due to abolition of passenger cars (sleeping carriages) and advanced use of tight couplers for diesel multiple units. Thus, the tight lock-type automatic couplers that were developed to compensate for the shortcomings of the automatic couplers have been switched over to tight couplers that are going to be introduced next.

(3) Tight coupler

The tight couplers maintain tightness at the coupling surface as with the case for the tight lock-type automatic coupler, and JSW began its production and sales in 1975. The tight couplers are used at almost all coupling locations on electric trains requiring coupling and uncoupling.

The tight coupler has a coupling mechanism that is different from the knuckle type of the automatic couplers and tight automatic couplers described earlier. The structure of the tight coupler is a rotating type where coupling is performed by the semicircular coupling locks as shown in Fig. 5 mutually turning into the lock chamber of the counterpart coupler. Coupling is performed automatically just by pushing the couplers mutually together, and uncoupling is performed by rotating the coupling lock counterclockwise by hand and engaging the lock key of the counterpart coupler, then separating the cars. The tight coupler can also be used in connection with the electric coupler. In addition, by providing an air cylinder to the coupling lock, a remote function can be added which allows the car separation procedure to be performed remotely from the control platform. In 2011, JSW began production and sales of tight couplers with an automatic uncoupling device shown in Photo 4.

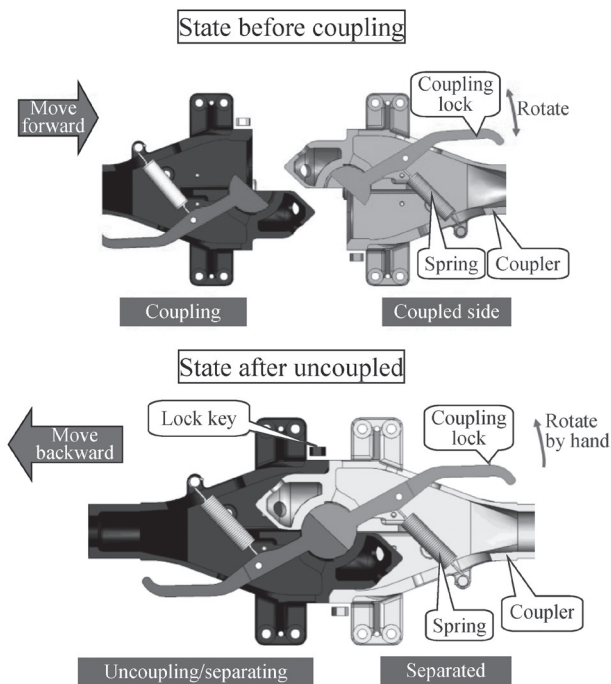

Fig. 5. Coupling Form and Mechanism of the Tight Coupler

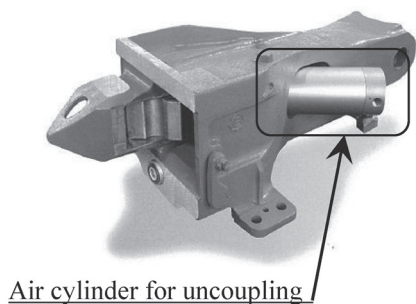

Photo 4. Tight Coupler (with Automatic Uncoupling Device)

The three couplers from (1) through (3) described above are all used at the areas where coupling and uncoupling between cars are required. However, the automatic coupler and the tight coupler are not required when cars do not need to be separated, except for maintenance. To respond to requests for reduced maintenance and lowering coupler costs, fixed couplers without an uncoupling device were also developed.

(4) NPA and NPB-type fixed couplers

In 1960, JSW developed the NPA-type and NPB-type series as couplers for intermediate cars of private railway companies.

The NPA-type and NPB-type fixed couplers (Photo 5) are composed of a simple parts structure such as a coupler body, tightening hardware and bolts as shown in Fig. 6, and secure coupler bodies together using tightening hardware. The contact

surface between the coupler body and tightening hardware is set at an angle, and this inclined surface works as a wedge to secure the coupler by tightening the bolts. A feature of this type of fixed coupler is that coupler force generated during travel is received at the tightening hardware, and therefore, pulling force does not apply to the four bolts.

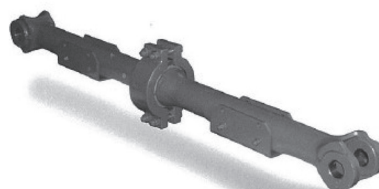

Photo 5. NPB-Type Fixed Coupler

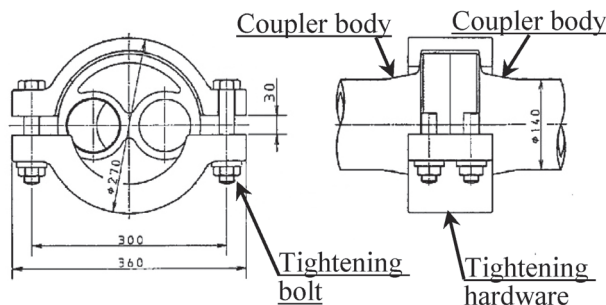

Fig. 6. Details of the Connecting Portion of NPA- and NPB-Type Fixed Couplers

(5) Semi-permanent coupler

On the other hand, the National Railway adopted a bolt-tightening type semi-permanent coupler (Photo 6) in 1979. This semi-permanent coupler, unlike the previous NPA-type and NPB-type fixed couplers, is structured in a way that four bolts are used to connect two coupler bodies directly and receive pulling force. The National Railway's adoption of this semi-permanent coupler accelerated introduction of fixed formation to trains in the Tokyo metropolitan area. JSW obtained a production right from the National Railway, and has achieved delivery records of over 5,000 semi-permanent coupler units today.

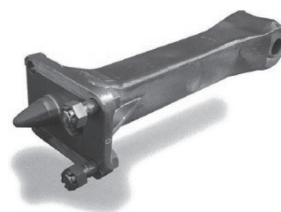

Photo 6. Semi-Permanent Coupler

(6) Rod-type coupler

The most simple form of coupler among the fixed couplers is the bar type coupler (Photo 7). The cost of the bar coupler is reduced even further than the semi-permanent coupler. The bar coupler is adopted on some JR cars, although the number is limited.

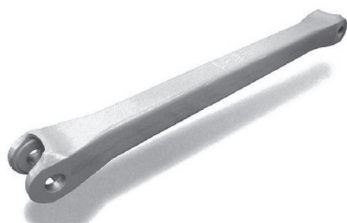

Photo 7. Rod-Type Coupler

(7) Compact tight coupler (built-in draft gear)

In 1987, JSW developed a coupler with a built-in rubber draft gear at the coupler shank targeted for monorails and new urban transportation systems. This coupler incorporates a draft gear and uses a simple mechanism where the coupler is mounted to a bracket on the car body side with a pin.

In recent years, overseas business inquiries have been increasing in association with overseas expansion by car manufacturers. JSW began to consider coupler device for overseas, and delivered our products to Singapore for new transportation systems in 2000. As a new function, this coupler device can be uncoupled when breakage occurs at a certain load by using shearing bolts on the car body mounting bracket based on requirements of overseas specifications.

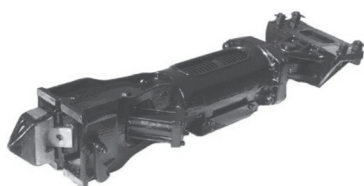

Photo 8. Compact Tight Coupler

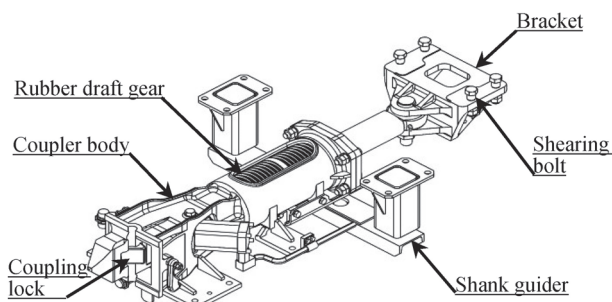

Fig. 7. Overview of Compact Tight Coupler

(8) Impact absorption type coupler (built-in emergency draft gear)

Collision safety in the case of the train crashing into obstacles such as rail crossings began to be questioned domestically the same as it was overseas. In 1993, JSW developed couplers with a built-in emergency draft gear inside that can absorb and mitigate impact. Domestically speaking, adoption of an imported emergency draft gear (viscous dumper) to JR East E217 series trains was the first usage in Japan. Then, to satisfy requests from JR East for lightweight and domestic production of the couplers above, JSW developed an impact absorption-type coupler (Photo 9) to which metal plasticity was applied. Today, the sales results exceed 1,500 units from JR East and others.

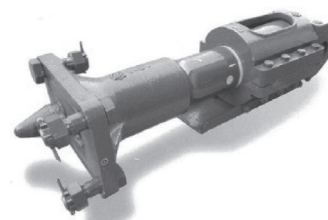

Photo 9. Impact Absorption-Type Semi-Permanent Coupler

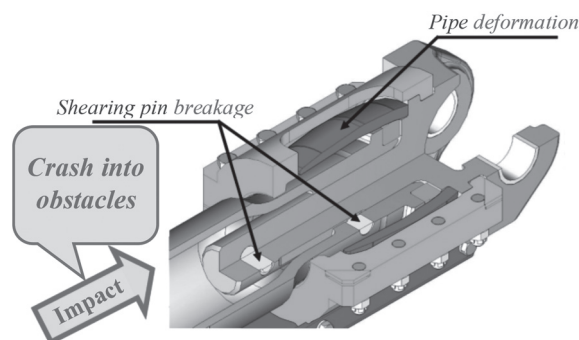

Fig. 8. Draft Gear Mechanism of Impact Absorption-Type Semi-Permanent Coupler

2.2 History of draft gears

Unlike couplers, draft gears cannot be seen from the station platform. During the era when the screw-type couplers were used, side buffers (parts with draft gear features) were mounted at both ends of cars. After the automatic couplers replaced the screw type, a new style was adopted where draft gears were installed onto a guide portion called a follower plate stop under the car end floor together with the couplers.

JSW's draft gear production began in 1957 with spiral spring draft gears using a metal spring (Photo 10) that were used on passenger cars and trains of private railway companies and Japan National Railways.

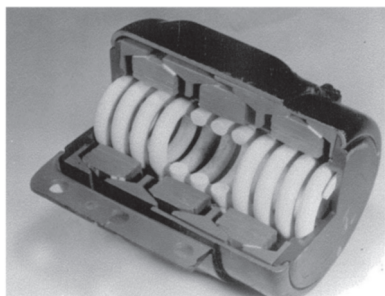

Photo 10. Spiral Spring Draft Gear

(1) Single-action type draft gear

For domestic railways, transportation volume was on the rise, and a speed increase in train formation was being sought. Consequently, railway companies considered improving the lack of buffer capacity of the spiral spring draft gears and their maintainability, and also began to search for draft gear materials to replace the metal spring. JSW launched development of domestic rubber draft gears. With the adoption of square-rubber block-type rubber draft gears by Japan National Railways in 1965, rubber draft gears started to be used widely on trains, locomotives, diesel multiple units and freight cars. As shown in Fig. 9, this draft gear is designed with a set of compressed rubber draft gears (this compressed state is called initial pressure) that are positioned between follower plates and assembled into a draft gear frame with front and back walls. The dimension of the draft gear is made slightly smaller than the car body installation dimension (follower plate stop) for easier mounting onto the car body. This is a so-called single-action type draft gear.

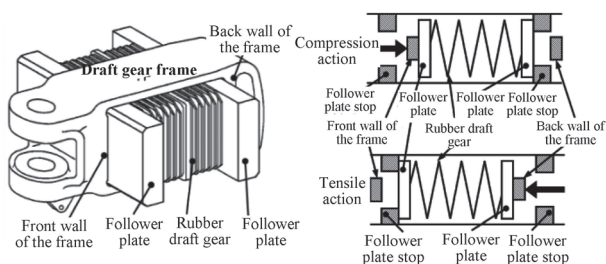

Fig. 9. Appearance and Structure of Single-Action Type Draft Gear

Because the rubber draft gear is assembled with initial pressure applied, this single-action type draft gear can rarely absorb or mitigate longitudinal impact during normal travel, and works only when receiving load equal to initial pressure or more. Therefore, as the mass transportation era began in the Showa fifties (late 1970s) due to the growing number of commuters in urban areas and also

passengers increasingly demanding improved riding comfort, JSW developed a rubber draft gear (RD16-type draft gear) for trains in 1978 that had a modified rubber pad shape and lowered initial pressure, and further more in 1987, also developed a low initial pressure draft gear (RD210-type draft gear) for Shinkansen trains.

(2) Double-action type draft gear

On the other hand, JSW reviewed draft gear structures to improve riding comfort, and designed a double-construction draft gear (RD011-type draft gear) in 1980 to respond to a complaint that the strong impact in sleeping carriages would disturb passengers' sleep.

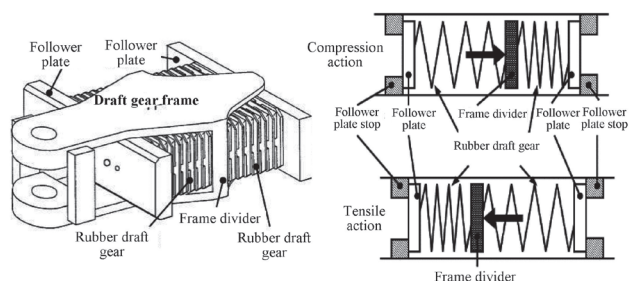

Fig. 10. Appearance and Structure of Double-Action Type Draft Gear

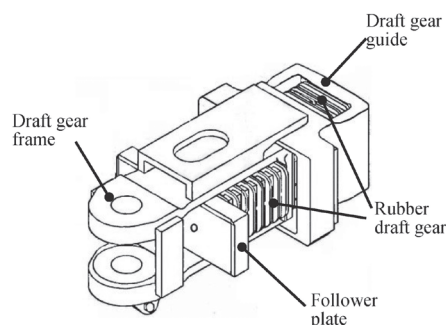

Fig. 11. Appearance of Double-action Type Draft Gear for Single-Replacement

As shown in Fig. 10, the double-action type draft gear is designed in a way that two sets of rubber draft gears are mounted both at the front and back of the center divider of the draft gear frame that has no front or back wall, and follower plates are mounted at the front and back of the draft gears. The draft gears and follower plates are free from the draft gear frame. Also, a double-action type draft gear for replacement (Fig. 11) was designed for cars equipped with a single-action type draft gear.

This mechanism cleared the problem that the single-action type could not absorb impact below the initial pressure. This type of draft gear was widely adopted from the RD011-type draft gear for

sleeping carriages as the first double-construction draft gear, to bullet trains and conventional train lines. The sales reached approximately 61,000 sets by March 2015, achieving approximately 70 percent share of the domestic draft gear market. Because the double-construction draft gear was adopted for newly produced cars during the National Railway era, JSW's draft gear also received a high valuation from the subsequent JR companies which led to wide adoption of JSW's draft gears.

(3) Draft gear with viscous-rubber combination use

In 2006, not only for passenger cars, JSW began to develop a new draft gear model together with the Railway Technical Research Institute as a preventive measure for load shifting on cargo shipping.

For traditional container cars for cargo shipping, the single-construction RD19-type draft gear is used.

However, the initial pressure is high and the buffer capacity is approximately 23 kJ which is more than other models. Therefore, a double-construction structure was designed to improve riding comfort (load shifting prevention), and at the same time a newly-structured draft gear with a viscous draft gear (Photo 11) was considered in order to compensate for lack of absorbed energy.

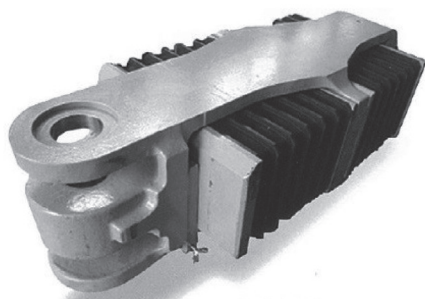

Photo 11. Draft Gear with Viscous-Rubber Combination Use

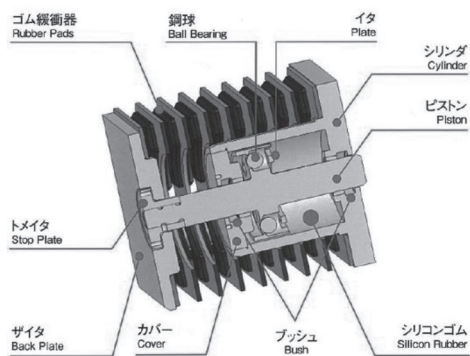

Fig. 12. Structure of Draft Gear with Viscous-Rubber Combination Use

This development article is called NRWS100-type, and has functions that take advantage of velocity dependency of a viscous draft gear. To absorb and mitigate energy, the double-action characteristics are used when impact velocity is slow, and both the double-action characteristics and a viscous draft gear are used when impact velocity is fast. This assures absorbed energy at the equivalent level of the current RD19-type draft gear.

During the development process, design verification was essential on velocity dependency of a viscous draft gear. JSW used to conduct testing at facilities of external agencies until then. However, by using a 200-t fatigue tester (max. excitation speed of 100 mm/s) at JSW's testing facility, testing became possible with assembled state assuming the train installation condition. It is expected that effective use of this tester will largely contribute to future development.

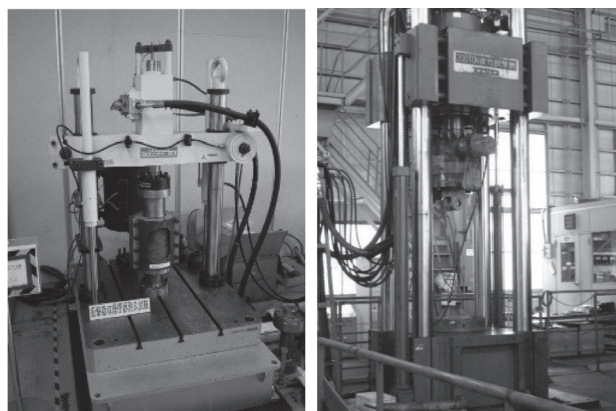

Photo 12. Appearance of Fatigue Tester in JSW Facility (Photo left: max. 100 kN, photo right: max. 2,000 kN)

This NRWS100-type new draft gear was tested on actual cars using commercial lines, and gained results that a longitudinal acceleration rate would be restrained more than by the current RD19-type draft gear, and that prevention of load shifting could be highly achievable. Through an endurance testing using commercial lines, JSW has been working on official adoption and commercialization.

### 3. Future outlook

JSW has focused on development and product launches of couplers and draft gears based on demands from domestic customers for nearly 60 years. However, while domestic population has been a declining trend and the flagging railway market has been also concerned, expansion of

orders and sales are major challenges to JSW.

The following describes future outlook of couplers and draft gears based on the previously mentioned background.

#### (1) Improving maintenance service and maintenance business

For railway business, JSW has been seeking customer satisfaction by developing and delivering new great products. From now on, however, prediction of product lifetime and maintenance information after delivery will be demanded in order for customers to be able to use products in stable, long-lasting quality.

To achieve this, JSW inspected aged deterioration of the rubber draft gear provided by customers, conducted notification services of proper replacement timing from expected product lifetime, and modified the product for a longer lifetime. As a result, achievements were made.

Because couplers wear over time, especially at their sliding portions, correcting work needs to satisfy standards for repair, by welding cladding and mending. Currently repair work is done at the maintenance shop of individual railway companies; however, this is expected to shift to a manufacturer dependent type. JSW will consider establishing structure to accommodate these needs.

#### (2) Dealing with overseas projects of domestic vehicle manufacturers

Accommodating overseas projects is also one of JSW's future challenges. Growth in the coupler and draft gear production is not expected due to the plateaued production number of newly produced vehicles in the domestic market, which requires JSW to work on immediate expansion of the market.

JSW has considered entering the overseas market for several years, and researched couplers and draft gears with overseas specifications through inquiries from several companies. Couplers and draft gears with overseas specifications differ greatly from the domestic design concept, and require more than ten-times the buffer capacity, as well as specifications of packaged devices of electric couplers and peripheral devices. Sometimes, project inquiries require JSW to meet certification requirements from a third-party certifier. JSW brought prototype devices to testing facilities in Europe to obtain certificates.

As a result of these activities, in 2014 JSW

gained its first contract of a coupler device (including electric couplers) with overseas specifications based on its proven domestic products.

JSW will continue working on delivering results on couplers and draft gears with overseas specifications to readily meet demand for overseas projects of domestic vehicle manufacturers.

## 4. Conclusion

In the beginning it was mentioned that JSW currently has only two rail products (couplers and draft gears), but there are possibilities to be exploited overseas. JSW will continue production and retail activities to further grow its business.

## References

- (1) "Development of Tight Coupler" by Shuzo Nakae (former-Railway Technical Research Institute)
- (2) "Coupling: Automatic Coupler (first, second, third)" by Yukio Sugiyama (National Railway Vehicle Design Office)
- (3) Japan Steel Works technical review No. 1 (1959) by Kuniyasu Kubota and Shuji Nishimura
- (4) Japan Steel Works technical review No. 2 (1959) by Hideo Mori, Kiyoshi Matsumoto, and Nobuo Sugano
- (5) Japan Steel Works technical review No. 4 (1960) by Soichi Suzuki, and Takeyuki Umenaka
- (6) Japan Steel Works technical review No. 6 (1961) by Soichi Suzuki, and Takeyuki Umenaka